

Integrator Series FPGAs: 40M X and 42M X Families

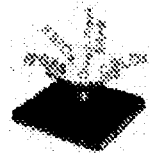

Features

High Capacity

- * 2,000 to 52,000 Available Logic Gates
- * Up to 3 Kbits Configurable Dual-Port SRAM
- * Fast Wide-Decode Circuitry
- * Up to 250 User-Programmable I/O Pins

High Performance

- * 5.6 ns Clock-to-Out
- * 250 MHz Performance
- * 5 ns Dual-Port SRAM Access
- * 100 MHz FIFOs
- * 7.5 ns 35-Bit Address Decode

Ease of Integration

- * Mixed Voltage Operation (5.0V or 3.3V I/O).
- * Synthesis-Friendly Architecture to Support ASIC Design Methodologies.
- * 95-100% Resource Utilization, Using Automatic Place and Route Tools with up to 100% Pin Fixing.

- * Deterministic, User-Controllable Timing Via DirectTime Software Tools.
- * MX Diagnostics and Debug Supported by Silicon Explorer.
- * Supported by Actel Designer Series Development System with Interfaces to Popular Design Environments Including Cadence, Exemplar, IST, Mentor Graphics, Synopsys, Synplicity, and Viewlogic.
- * Low Power Consumption (less than 100 A in Stand-By Mode).
- * IEEE Standard 1149.1 (JTAG) Boundary Scan Testing
- * 5.0V and 3.3V Programmable PCI-Compliant I/O.

General Description

The newest additions to Actel's Integrator Series of programmable logic devices, the 40MX and 42MX families, provide system logic designers with a high performance, cost-effective ASIC alternative in a single FPGA.

The MX device architecture is based on Actel's patented antifuse technology implemented in a 0.45 triple-metal

Integrator Series Product Profile

| Device | A40MX82 | A40MX04 | A42MX09 | A42MX16 | A42MX24 | A42MX36 | A42MX52 |
|--|-------------------------------|---------------------------------------|--|---|---------------------------------|-------------------------|----------------|
| Capacity | | | | | | | |
| Gates | 2,000 | 4,000 | 9,000 | 16,000 | 24,000 | 36,000 | 52,000 |
| ASIC-Equivalent Gates | 1,200 | 2,000 | 4,000 | 8,000 | 14,000 | 20,000 | 30,000 |
| SRAM Bits | N/A | N/A | N/A | N/A | N/A | 2,560 | 3,072 |
| Logic Modules | | | | | | | |
| Sequential | — | — | 348 | 624 | 954 | 1,230 | 1,888 |
| Combinatorial | 295 | 547 | 336 | 608 | 912 | 1,184 | 1,833 |
| Decode | — | — | N/A | N/A | 24 | 24 | 28 |
| Clock-to-Out | 9.5 ns | 9.5 ns | 5.6 ns | 6.1 ns | 6.1 ns | 6.3 ns | 7.2 ns |
| SRAM Modules (64x4 or 32x8) | N/A | N/A | N/A | N/A | N/A | 10 | 12 |
| Dedicated Flip-Flops | — | — | 348 | 624 | 954 | 1,230 | 1,888 |
| Maximum Flip-Flops | 147 | 273 | 516 | 928 | 1,410 | 1,822 | 2,804 |
| Clocks | 1 | 1 | 2 | 2 | 2 | 6 | 6 |
| User I/O (Maximum) | 57 | 69 | 104 | 140 | 176 | 202 | 250 |
| JTAG | No | No | No | No | Yes | Yes | Yes |
| Packages | PL44 PL68 PQ100 VQ80 | PL44 PL68 PL84 PQ100 VQ80 | PL84 PQ100 PQ160 TQ176 VQ100 | PL84 PQ100 PQ160 PQ208 TQ176 VQ100 | PL84 PQ160 PQ208 TQ176 | PQ208 RQ240 BG304 | RQ208 RQ240 |



CMOS process. With capacities ranging from 2,000 to 52,000 gates, the synthesis-friendly MX devices provide datapaths up to 250 MHz, are live on power-up, and deliver up to five times lower stand-by power consumption than any other FPGA device. Actel's MX FPGAs provide up to 250 I/Os, and are available in a wide variety of packages and speed grades.

Actel's 42MX family of FPGAs also feature MultiPlex I/O, an advanced architectural feature that supports mixed voltage systems, enables programmable PCI, delivers high-performance operation at both 5.0V and 3.3V, and provides a low-power mode.

MultiPlex I/O supports the most common voltage standards today: pure 5.0V operation, pure 3.3V operation, and mixed 3.3V operation with 5.0V operation input tolerance for maximum performance. Internal array performance is retained in 3.3V systems by using complimentary pass gates that operate as fast at 3.3V as they do at 5.0V.

MultiPlex I/O includes selectable PCI output drives in certain 42MX devices, enabling 100% PCI-compliance for both 5.0V and 3.3V systems. For low-power systems, MultiPlex I/O is used to turn off all inputs and outputs to cut current consumption to below 100 A.

The 42MX FPGA devices also include system-level features such as JTAG, dual-port SRAM, and fast wide-decode modules. The 42MX family offers the industry's fastest dual-port SRAM for implementing fast FIFOs, LIFOs, and temporary data storage. The large number of storage elements can efficiently address applications requiring wide datapath manipulation, and can perform transformation functions such as telecommunications, networking, and DSP. The 42MX FPGAs were designed to integrate system logic that is typically implemented in multiple CPLDs, PALs and FPGAs.

Ordering Information

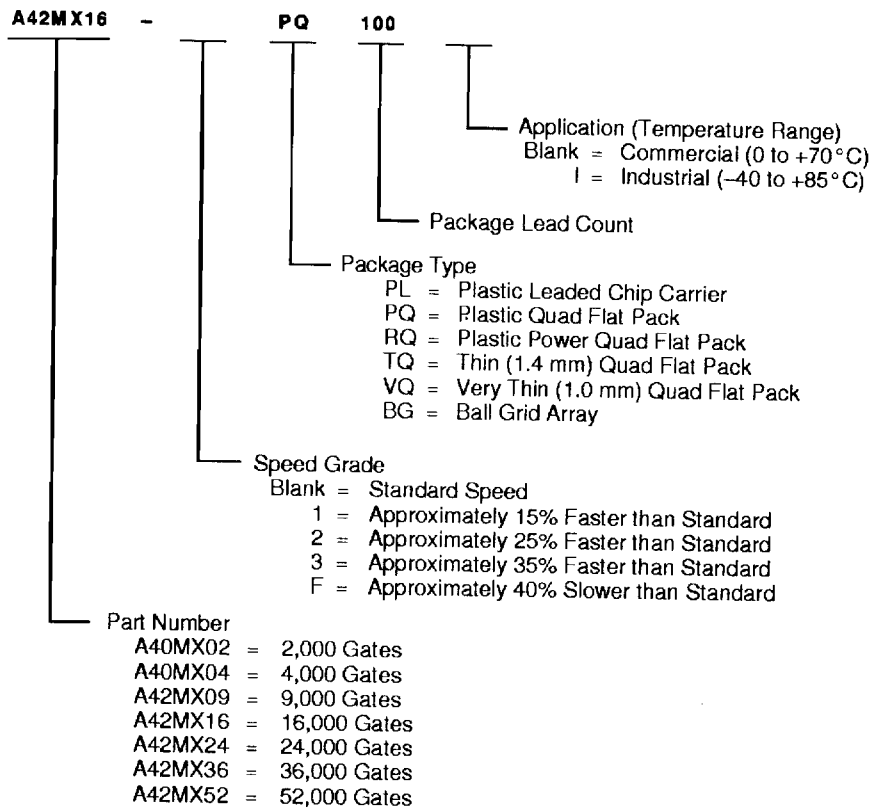



Integrator Series devices are supported by Actel's Designer Series development software, which provides a seamless integration into many ASIC design flows. The Designer Series development tools offer automatic place and route (even with pre-assigned pins), static timing analysis, user programming, and debug and diagnostic probe capabilities. The DirectTime tool provides deterministic and controllable timing, allowing the designer to specify the performance requirements of individual paths and system clocks. Using these specifications, the software will automatically optimize the placement and routing of the logic to meet the constraints. Also included with the Designer Series tools is Actel's ACTgen Macro Builder. ACTgen allows the designer quickly to build fast, efficient logic functions such as counters, adders, FIFOs, and RAM.

The Designer Series tools provide designers with the capability to move up to high-level description languages,

such as VHDL and Verilog-HDL, or to use schematic design entry with interfaces to most EDA tools. Designer Series is supported on 486 and Pentium PCs and on Sun and HP workstations. The software provides CAE interfaces to Cadence, Mentor Graphics, Escalade, OrCAD, and Viewlogic design environments. Additional development tools are supported through Actel's Industry Alliance Program, including Data I/O (ABEL FPGA) and MINC.

Actel's MX FPGAs provide a high-performance, single-chip solution for shortening the system design and development cycle, and they offer a cost-effective alternative to ASICs. The 40MX and 42MX devices are an excellent choices for integrating logic that is currently implemented in multiple PALs, CPLDs, and FPGAs. Example applications include high-speed controllers and address decoding, peripheral bus interfaces, DSP, and co-processor functions.

Plastic Device Resources

| Device | User I/Os | | | | | | | | | | | |
|---------|----------------|----------------|----------------|----------------|-----------------|-----------------|-----------------|-----------------|-----------------|-----------------|-----------------|----------------|
| | PLCC 44-Pin | PLCC 68-Pin | PLCC 84-Pin | VQFP 80-Pin | VQFP 100-Pin | PQFP 100-Pin | PQFP 160-Pin | PQFP 208-Pin | RQFP 208-Pin | RQFP 240-Pin | TQFP 176-Pin | BGA 304-Pin |
| A40MX02 | 34 | 57 | — | 57 | — | 57 | — | — | — | — | — | — |
| A40MX04 | 34 | 57 | 69 | 69 | — | 69 | — | — | — | — | — | — |
| A42MX09 | — | — | 72 | — | 83 | 83 | 100 | — | — | — | 103 | — |
| A42MX16 | — | — | 72 | — | 83 | 83 | 125 | 140 | — | — | 140 | — |
| A42MX24 | — | — | 72 | — | — | — | 125 | 176 | — | — | 150 | — |
| A42MX36 | — | — | — | — | — | — | — | 176 | — | 202 | — | 202 |
| A42MX52 | — | — | — | — | — | — | — | — | 176 | 202 | — | — |

Package Definitions (Consult your local Actel sales representative for product availability.)

PLCC = Plastic Leaded Chip Carrier, PQFP = Plastic Quad Flat Pack, TQFP = Thin Quad Flat Pack, VQFP = Very Thin Quad Flat Pack, RQFP = Plastic Power Quad Flat Pack, BGA = Enhanced Ball Grid Array

Pin Description

CLK, CLKA, CLKB

Clock Clock A and Clock B (Input)

TTL clock inputs for clock distribution networks. The clock input is buffered prior to clocking the logic modules. This pin can also be used as an I/O.

DCLK Diagnostic Clock (Input)

TTL clock input for diagnostic probe and device programming. DCLK is active when the MODE pin is HIGH. This pin functions as an I/O when the MODE pin is LOW.

GND Ground (Input)

Input LOW supply voltage.

I/O Input/Output (Input, Output)

Input, output, tri-state, or bi-directional buffer. Input and output levels are compatible with standard TTL and CMOS specifications. Unused I/O pins are automatically driven LOW by the Designer Series software.

MODE Mode (Input)

Controls the use of multifunction pins (DCLK, PRA, PRB, SDI, TDO). To provide ActionProbe capability, the MODE pin should be held HIGH. To facilitate this the MODE pin should be terminated to GND through a 10K resistor so that the MODE pin can be pulled HIGH when required.

NC No Connection

Not connected to circuitry within the device.

PRB, I/O Probe A (Output)

Used to output data from any user-defined design node within the device. This independent diagnostic pin is used in conjunction with the Probe B pin to allow real-time diagnostic output of any signal path within the device. The Probe A pin can be used as a user-defined I/O when debugging has been completed. The pin's probe capabilities can be permanently disabled to protect programmed design confidentiality. PRA is active when the MODE pin is HIGH. This pin functions as an I/O when the MODE pin is LOW.

PRB, I/O Probe B (Output)

Used to output data from any user-defined design node within the device. This independent diagnostic pin is used in conjunction with the Probe A pin to allow real-time diagnostic output of any signal path within the device. The Probe B pin can be used as a user-defined I/O when debugging has been completed. The pin's probe capabilities can be permanently disabled to protect programmed design confidentiality. PRB is active when the MODE pin is HIGH. This pin functions as an I/O when the MODE pin is LOW.

QCLKA/B,C,D Quadrant Clock (Input/Output)

Quadrant clock inputs. When not used as a register control signal, these pins can function as general-purpose I/O.

SDI Serial Data Input (Input)

Serial data input for diagnostic probe and device programming. SDI is active when the MODE pin is HIGH. This pin functions as an I/O when the MODE pin is LOW.

TCK Test Clock

Clock signal to shift the JTAG data into the device. This pin functions as an I/O when the JTAG fuse is not programmed.

TDI Test Data In

Serial data input for JTAG instructions and data. Data is shifted in on the rising edge of TCLK. This pin functions as an I/O when the JTAG fuse is not programmed.

TDO Test Data Out

Serial data output for JTAG instructions and test data. This pin functions as an I/O when the JTAG fuse is not programmed.

TMS Test Mode Select

Serial data input for JTAG test mode. Data is shifted in on the rising edge of TCLK. This pin functions as an I/O when the JTAG fuse is not programmed.

V_{CC} Supply Voltage (Input)

Input HIGH supply voltage.

V_{CCA} Supply Voltage (Input)

Input HIGH supply voltage, supplies array core only.

V_{CCI} Supply Voltage (Input)

Input HIGH supply voltage, supplies I/O cells only.

LP Low Power Mode

Controls the low power mode of all 42MX devices. This pin must be set HIGH to switch the device to low power mode. In low power mode, all I/Os are tri-stated, all input buffers are turned OFF, and the core of the devices is turned OFF. To exit the LOW power mode, the LP pin must be set LOW. This mode is enabled 800 nsec after LP pin is set HIGH.

Note: TCK, TDI, TDO, TMS are available only on devices containing JTAG circuitry.

Connecting V_{CC} on MX Devices

40MX

The 40MX FPGAs will operate in 5.0V only systems or 3.3V only systems.

| V _{CC} | Input | Output |
|-----------------|-------|--------|
| 3.3V | 3.3V | 3.3V |
| 5.0V | 5.0V | 5.0V |

42MX

The 42MX FPGAs will operate in 5.0V only systems, 3.3V only systems, or mixed 5.0V/3.3V systems.

| V _{CCA} | V _{CCI} | Input | Output |
|------------------|------------------|------------|--------|
| 3.3V | 3.3V | 3.3V | 3.3V |
| 5.0V | 3.3V | 3.3V, 5.0V | 3.3V |
| 5.0V | 5.0V | 5.0V | 5.0V |

MX Architectural Overview

The 40MX and 42MX devices are composed of fine-grained building blocks that enable fast, efficient logic designs. All devices within the Integrator Series are composed of logic modules, routing resources, clock networks, and I/O modules, which are the building blocks for designing fast logic designs. In addition, a subset of devices contain embedded dual-port SRAM and wide decode modules. The dual-port SRAM modules are optimized for high-speed datapath functions such as FIFOs, LIFOs, and scratchpad memory. The "Integrator Series Product Profile" on page 1 lists the specific logic resources contained within each device.

Logic Modules

The 40MX logic module is an eight-input, one-output logic circuit designed to implement a wide range of logic functions with efficient use of interconnect routing resources (Figure 1).

The logic module can implement the four basic logic functions (NAND, AND, OR, and NOR) in gates of two, three, or four inputs. Each function may have many versions with different combinations of active LOW inputs. The logic module can also implement a variety of D-latches, exclusivity functions, AND-ORs, and OR-ANDs. No dedicated hard-wired latches or flip-flops are required in the array, since latches and flip-flops can be constructed from logic modules wherever needed in the application.

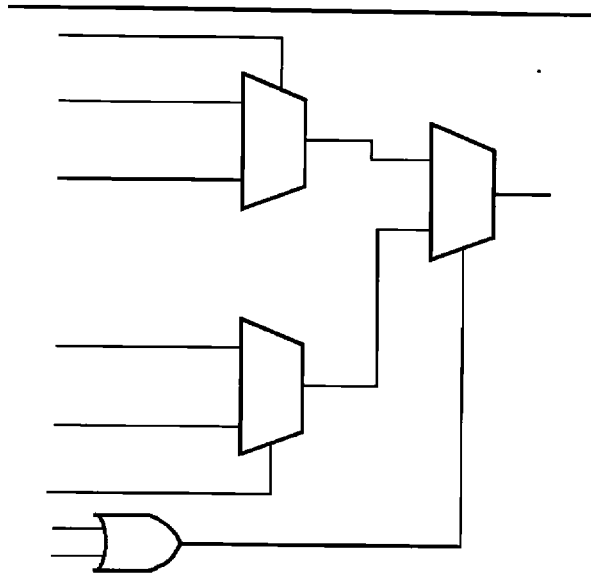

Figure 1 • 40MX Logic Module

The 42MX devices contain three types of logic modules: combinational (C-modules), sequential (S-modules), and decode (D-modules).

The C-module is shown in Figure 2 and implements the following function:

$$Y = !S1 * !S0 * D00 + !S1 * S0 * D01 + S1 * !S0 * D10 + S1 * S0 * D11$$

where

$$S0 = A0 * B0$$

$$S1 = A1 + B1$$

The S-module shown in Figure 3 is designed to implement high-speed sequential functions within a single logic module. The S-module implements the same combinational logic function as the C-module while adding a sequential element. The sequential element can be configured as either a D flip-flop or a transparent latch. To increase flexibility, the S-module register can be bypassed so that it implements purely combinational logic.

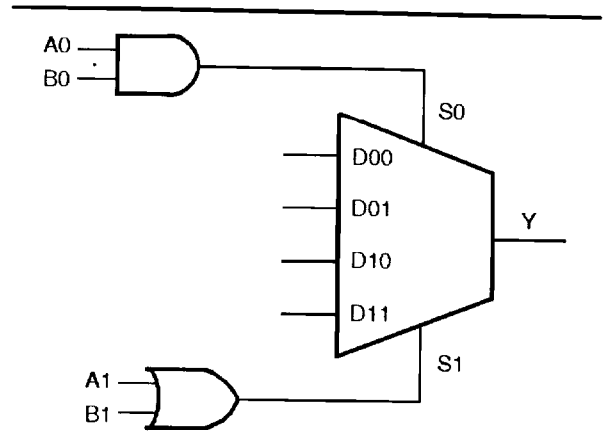

Figure 2• C-Module Implementation

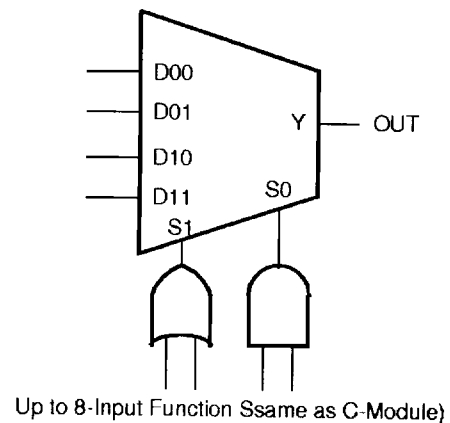
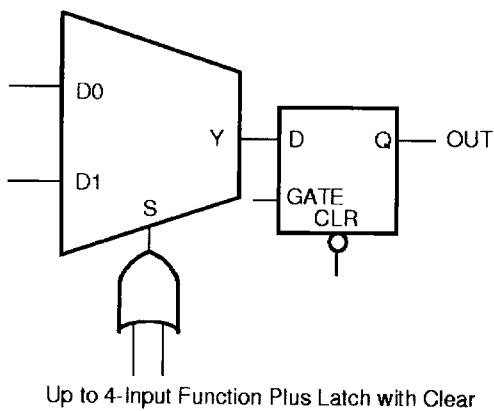
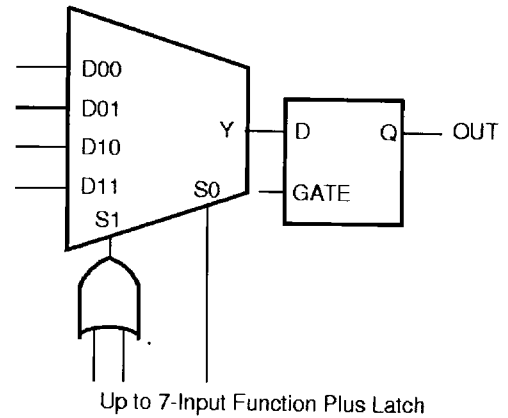
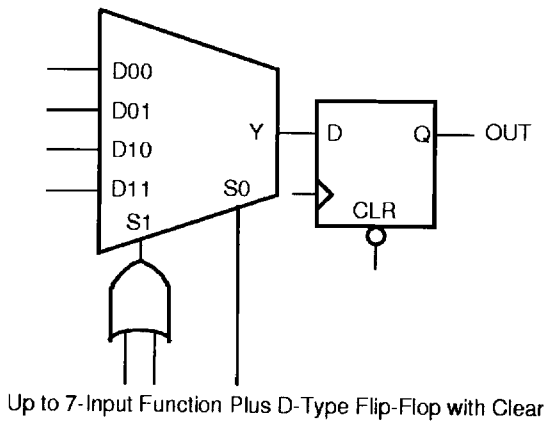

Figure 3• S-Module Implementation

Some of the 42MX devices contain a third type of logic module, D-modules, which are arranged around the peripheries of the devices. D-modules contain wide-decode circuitry, which provides a fast, wide-input AND function similar to that found in product term architectures (Figure 4). The D-module allows 42MX devices to perform wide-decode functions at speeds comparable to CPLDs and PAL devices. The output of the D-module has a programmable inverter for active HIGH or LOW assertion. The D-module output is hard-wired to an output pin, or it can be fed back into the array to be incorporated into other logic.

Dual-Port SRAM Modules

Several 42MX devices contain dual-port SRAM modules that have been optimized for synchronous or asynchronous applications. The SRAM modules are arranged in 256-bit blocks that can be configured as 32x8 or 64x4. (Refer to the "Integrator Series Product Profile" table, on page 1, for the number of SRAM blocks within a particular device.) SRAM

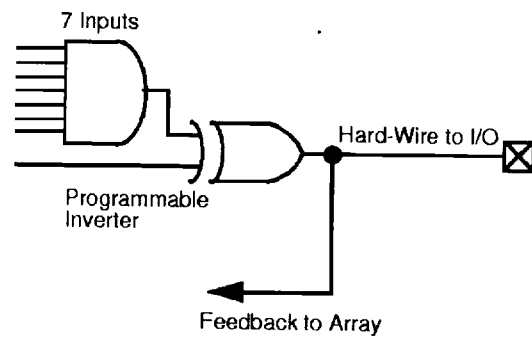

Figure 4• D-Module Implementation

modules can be cascaded together to form memory spaces of user-definable width and depth. A block diagram of the 42MX dual-port SRAM block is shown in Figure 5.

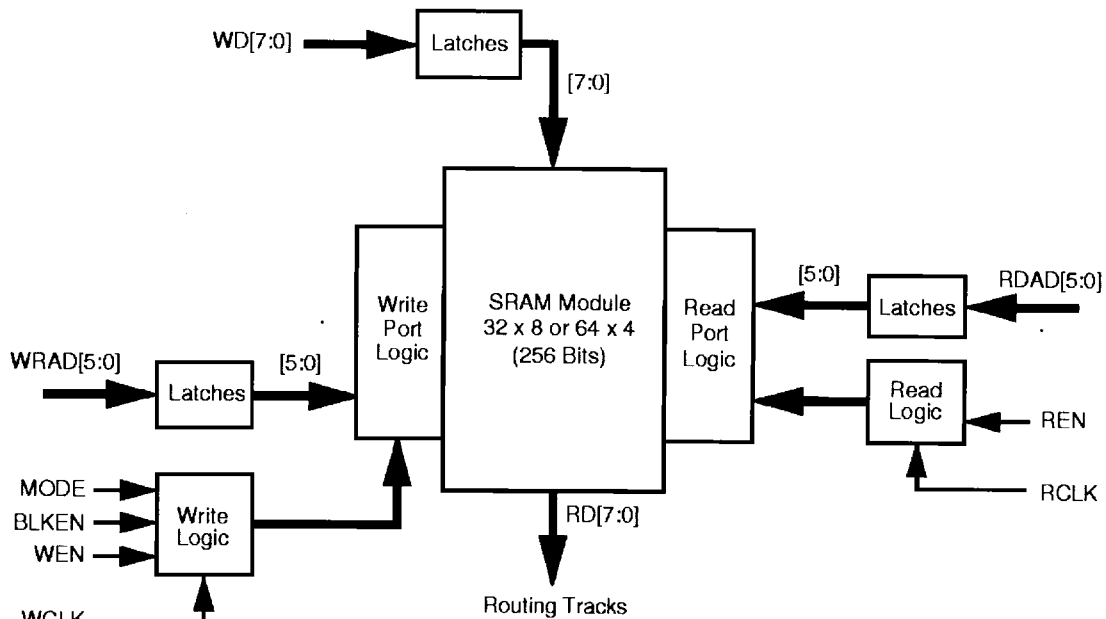

Figure 5• 42MX Dual-Port SRAM Block

The 42MX SRAM modules are true dual-port structures containing independent read and write ports. Each SRAM module contains six bits of read and write addressing (RDAD[5:0] and WRAD[5:0], respectively) for 64x4-bit blocks. When configured in byte mode, the highest order address bits (RDAD5 and WRAD5) are not used. The read and write ports of the SRAM block contain independent clocks (RCLK and WCLK) with programmable polarities offering

active HIGH or LOW implementation. The SRAM block contains eight data inputs (WD[7:0]), and eight outputs (RD[7:0]) which are connected to segmented vertical routing tracks.

The 42MX dual-port SRAM blocks provide an optimal solution for high-speed buffered applications requiring fast FIFO and LIFO queues. Actel's ACTgen Macro Builder provides the capability to quickly design memory functions, such as FIFOs,

LIFOs, and RAM arrays. In addition, unused SRAM blocks can be used to implement registers for other logic within the design.

MultiPlex I/O Modules

The MultiPlex I/O modules provide the interface between the device pins and the logic array. The top of Figure 6 is a block diagram of the 42MX I/O module. A variety of user functions, determined by a library macro selection, can be implemented in the module. (Refer to the Macro Library Guide for more information.) All 42MX I/O modules contain a tri-state buffer, with input and output latches that can be configured for input, output, or bi-directional operation.

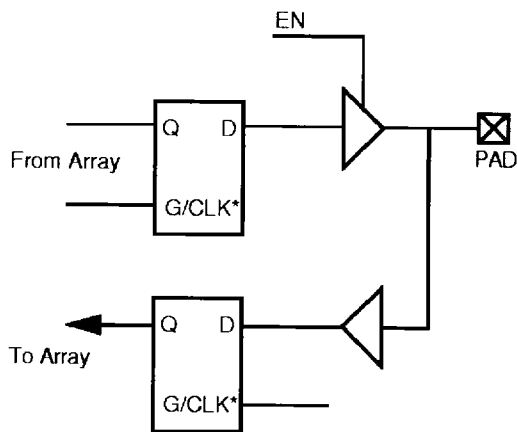

* Can be Configured as a Latch or D Flip-Flop (Using C-Module)

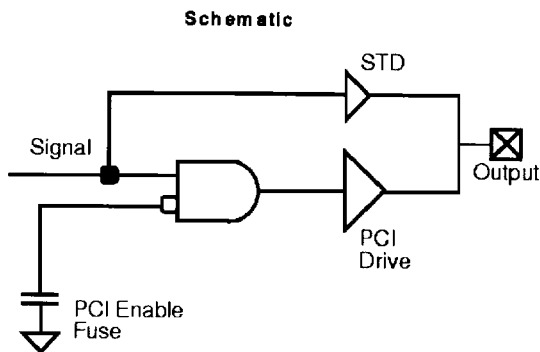

Figure 6• I/O Module

The Integrator Series devices contain flexible I/O structures, where each output pin has a dedicated output-enable control. The I/O module can be used to latch input or output data, or both, providing a fast set-up time. In addition, the Actel Designer Series software tools can build a D-type flip-flop

using a C-module to register input and output signals. To achieve 5.0V or 3.3V PCI-compliant output drives on A42MX24, A42MX36, and A42MX52 devices, a chip-wide PCI fuse is programmed. When the PCI fuse is not programmed, output drive is standard. (See the bottom portion of Figure 6.)

Actel's Designer Series development tools provide a design library of I/O macrofunctions that can implement all I/O configurations supported by the MX FPGAs.

Routing Structure

The MX architecture uses vertical and horizontal routing tracks to interconnect the various logic and I/O modules. These routing tracks are metal interconnects that may be either of continuous length or broken into pieces called segments. Varying segment lengths allows the interconnect of over 90% of design tracks to occur with only two antifuse connections. Segments can be joined together at the ends using antifuses to increase their lengths up to the full length of the track. All interconnects can be accomplished with a maximum of four antifuses.

Horizontal Routing

Horizontal channels are located between the rows of modules and are composed of several routing tracks. The horizontal routing tracks within the channel are divided into one or more segments. The minimum horizontal segment length is the width of a module pair, and the maximum horizontal segment length is the full length of the channel. Any segment that spans more than one-third the row length is considered a long horizontal segment. A typical channel is shown in Figure 7. Non-dedicated horizontal routing tracks are used to route signal nets; dedicated routing tracks are used for global clock networks and for power and ground tie-off tracks.

Vertical Routing

Another set of routing tracks run vertically through the module. Vertical tracks are of three types: input, output, and long, and are also divided into one or more segments. Each segment in an input track is dedicated to the input of a particular module; each segment in an output track is dedicated to the output of a particular module. Long segments are uncommitted and can be assigned during routing. Each output segment spans four channels (two above and two below), except near the top and bottom of the array, where edge effects occur. Long vertical tracks contain either one or two segments. An example of vertical routing tracks and segments is shown in Figure 7.

Antifuse Structures

An antifuse is a "normally open" structure as opposed to the normally closed fuse structure used in PROMs or PALs. The use of antifuses to implement a programmable logic device results in highly-testable structures as well as efficient

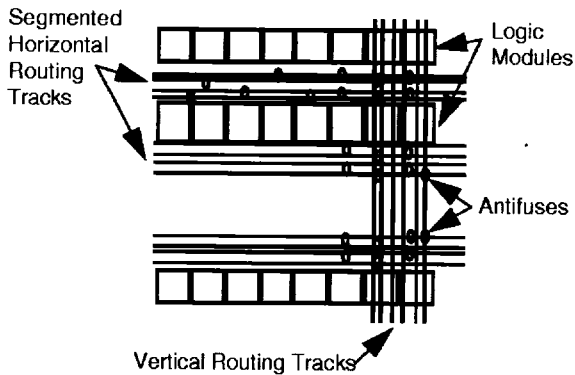

Figure 7• Routing Structure

programming algorithms. The structure is highly-testable because there are no pre-existing connections; therefore, temporary connections can be made using pass transistors. These temporary connections can isolate individual antifuses to be programmed and individual circuit structures to be tested, which can be done before and after programming. For example, all metal tracks can be tested for continuity and shorts between adjacent tracks, and the functionality of all logic modules can be verified.

Clock Networks

The 40MX devices have one global CLK distribution network. Two low-skew, high-fanout clock distribution networks are provided in each 42MX device. These networks are referred to as CLK0 and CLK1. Each network has a clock module (CLKMOD) that selects the source of the clock signal and may be driven as follows:

- * Externally from the CLKA pad
- * Externally from the CLKB pad
- * Internally from the CLKINA input
- * Internally from the CLKINB input

The clock modules are located in the top row of I/O modules. Clock drivers and a dedicated horizontal clock track are located in each horizontal routing channel.

The user controls the clock module by selecting one of two clock macros from the macro library. The macro CLKBUF is used to connect one of the two external clock pins to a clock network, and the macro CLKINT is used to connect an internally-generated clock signal to a clock network. Since both clock networks are identical, the user does not care whether CLK0 or CLK1 is being used. The clock input pads can also be used as normal I/Os, bypassing the clock networks. (See Figure 8.)

The 42MX devices that contain SRAM modules have four additional register control resources, called quadrant clock networks (Figure 9). Each quadrant clock provides a local,

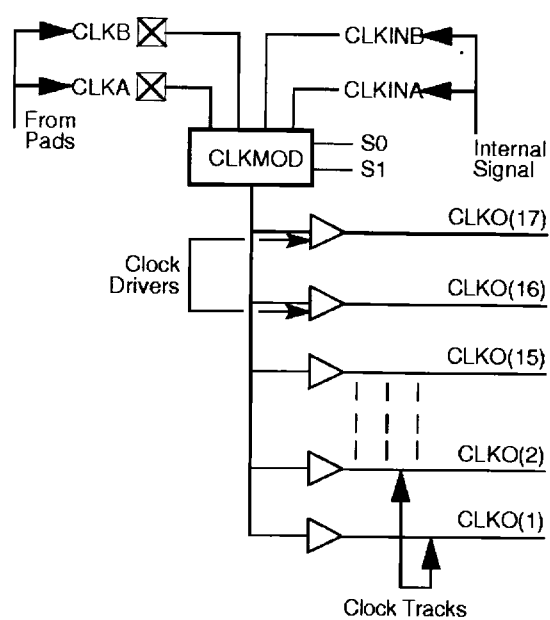

Figure 8• Clock Networks

high-fanout resource to the contiguous logic modules within its quadrant of the device. Quadrant clock signals can originate from specific I/O pins or from the internal array and can be used as a secondary register clock, register clear, or output enable.

Test Circuitry

Both 40MX and 42MX devices provide the means to test and debug a design once it is programmed into a device. The 40MX and 42MX devices contain Actel's test circuitry. Once a device has been programmed, the ActionProbe test circuitry allows the designer to probe any internal node during device operation to aid in debugging a design. In addition, 42MX devices contain IEEE Standard 1149.1 (JTAG) Boundary Scan Test.

JTAG Boundary Scan Testing (BST)

Device pin spacing is decreasing with the advent of fine-pitch packages such as TQFP and BGA, and manufacturers are routinely implementing surface-mount technology with multilayer PC boards. The Joint Test Action Group (JTAG) developed IEEE Standard 1149.1 Boundary Scan Test to facilitate board-level testing during manufacturing.

IEEE Standard 1149.1 defines a four-pin Test Access Port (TAP) interface for testing integrated circuits in a system. The 42MX family provides four JTAG BST pins: Test Data In (TDI), Test Data Out (TDO), Test Clock (TCLK), and Test Mode Select (TMS). Devices are configured in a JTAG "chain" where BST data can be transmitted serially between devices via TDO-to-TDI interconnections. The TMS and TCLK signals

are shared among all devices in the JTAG chain so that all components operate in the same state.

The 42MX family implements a subset of the IEEE Standard 1149.1 BST instruction in addition to a private instruction, which allows the use of Actel's ActionProbe facility with JTAG BST. Refer to the IEEE Standard 1149.1 specification for detailed information regarding JTAG testing.

JTAG Architecture

The 42MX JTAG BST circuitry consist of a Test Access Pprt (TAP) controller, JTAG instruction register, a JPROBE register, a bypass register, and a boundary scan register. Figure 10 is a block diagram of the 42MX JTAG circuitry.

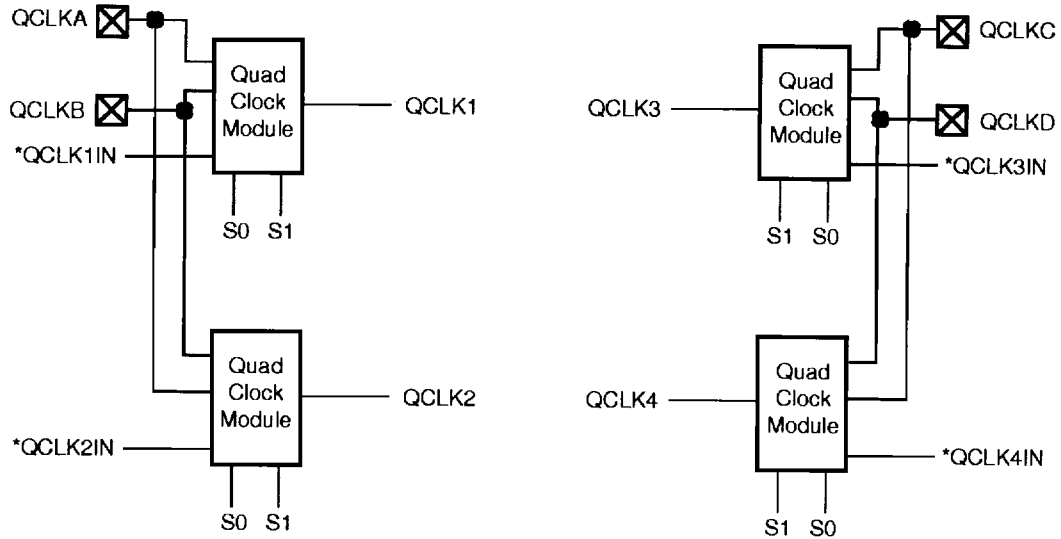

*QCLK1IN, QCLK2IN, QCLK3IN, and QCLK4IN are internally-generated signals.

Figure 9• Quadrant Clock Network

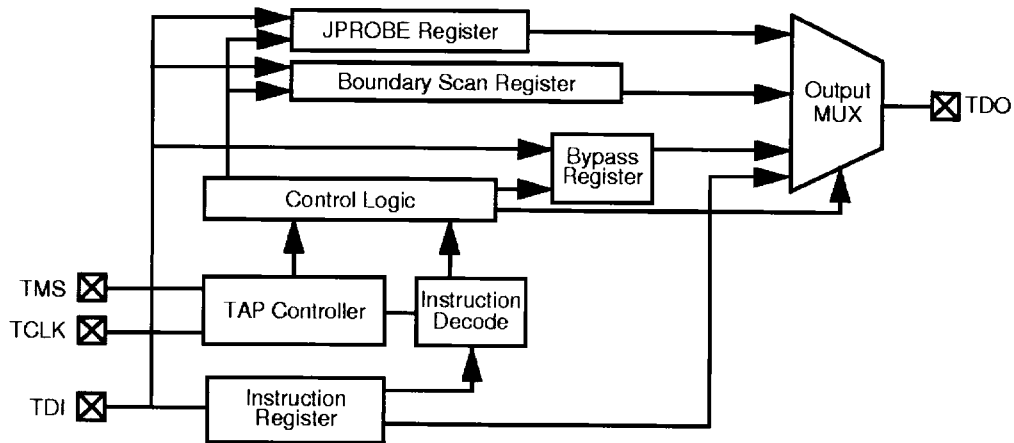

Figure 10• JTAG BST Circuitry

When a device is operating in JTAG BST mode, four I/O pins are used for the TDI, TDO, TMS, and TCLK signals. An active reset (nTRST) pin is not supported; however, the 42MX contains power-on circuitry that resets the JTAG BST circuitry upon power-up. During normal device operation, the JTAG pins should be held LOW to disable the JTAG circuitry. The following table summarizes the functions of the JTAG BST signals.

| JTAG Signal | Name | Function |
|-------------|------------------|--|
| TDI | Test Data In | Serial data input for JTAG instructions and data. Data is shifted in on the rising edge of TCLK. |
| TDO | Test Data Out | Serial data output for JTAG instructions and test data. |
| TMS | Test Mode Select | Serial data input for JTAG test mode. Data is shifted in on the rising edge of TCLK. |
| TCLK | Test Clock | Clock signal to shift the JTAG data into the device. |

JTAG BST Instructions

JTAG BST testing within the 42MX devices is controlled by a Test Access Port (TAP) state machine. The TAP controller drives the three-bit instruction register, a bypass register, and the boundary scan data registers within the device. The TAP controller uses the TMS signal to control the JTAG testing of the device. The JTAG test mode is determined by the bitstream entered on the TMS pin. The table in the next column describes the JTAG instructions supported by the 42MX.

ActionProbe

If a device has been successfully programmed and the security fuse has not been programmed, any internal logic or I/O module output can be observed in real time using the ActionProbe circuitry, PRA and/or PRB pins and Actel's Silicon Explorer diagnostic and debug tool kit. Refer to "Using the ActionProbe for System-Level Debug" application note for further information.

| Test Mode | Code | Description |
|---------------------|------|--|
| EXTEST | 000 | Allows the external circuitry and board-level interconnections to be tested by forcing a test pattern at the output pins and capturing test results at the input pins. |
| SAMPLE/ PRELOAD | 001 | Allows a snapshot of the signals at the device pins to be captured and examined during device operation. |
| INTEST | 010 | Refer to the IEEE Standard 1149.1 specification. |
| JPROBE | 011 | A private instruction allowing the user to connect Actel's Micro Probe registers to the JTAG chain. |
| USER INSTRUCTION | 100 | Allows the user to build application-specific instructions such as RAM READ and RAM WRITE. |
| HIGH Z | 101 | Refer to the IEEE Standard 1149.1 specification. |
| CLAMP | 110 | Refer to the IEEE Standard 1149.1 specification. |
| BYPASS | 111 | Enables the bypass register between the TDI and TDO pins. The test data passes through the selected device to adjacent devices in the JTAG chain. |

5.0V Operating Conditions
Mixed 5.0V/3.3V Operating Conditions

Absolute Maximum Ratings ¹

Free Air Temperature Range

| Symbol | Parameter | Limits | Units |
|------------------|--------------------------------------|-------------------------------|-------|
| V _{CC} | DC Supply Voltage | -0.5 to +7.0 | V |
| V _I | Input Voltage | -0.5 to V _{CC} + 0.5 | V |
| V _O | Output Voltage | -0.5 to V _{CC} + 0.5 | V |
| I _{IO} | I/O Source/Sink Current ² | ±20 | mA |
| T _{STG} | Storage Temperature | -65 to +150 | °C |

Notes:

- Stresses beyond those listed under "Absolute Maximum Ratings" may cause permanent damage to the device. Exposure to absolute maximum rated conditions for extended periods may affect device reliability. Device should not be operated outside the Recommended Operating Conditions.
- Device inputs are normally high impedance and draw extremely low current. However, when input voltage is greater than V_{CC} + 0.5V or less than GND - 0.5V, the internal protection diode will be forward-biased and can draw excessive current.

Recommended Operating Conditions

| Parameter | Commercial | Industrial | Units |
|--------------------------------|--------------|------------|------------------|
| Temperature Range ¹ | 0 to +70 | -40 to +85 | °C |
| Power Supply Tolerance | ±5 | ±10 | %V _{CC} |
| V _{CCI} | 4.75 to 5.25 | 4.5 to 5.5 | V |
| V _{CCA} | 4.75 to 5.25 | 4.5 to 5.5 | V |
| V _{CC} | 4.75 to 5.25 | 4.5 to 5.5 | V |
| V _{CCI} ² | 3.14 to 3.47 | 3.0 to 3.6 | V |

Note:

- Ambient temperature (T_A) is used for commercial and industrial.
- Operating condition for I/O in mixed voltage mode.

Electrical Specifications

| Symbol | Parameter | Commercial | | Commercial -F | | Industrial | | Units |
|--|---|-------------------------------------|-----------------------|---------------|-----------------------|------------|-----------------------|-------|
| | | Min. | Max. | Min. | Max. | Min. | Max. | |
| V _{OH} ¹ | (I _{OH} = -10 mA) ² | 2.4 | | 2.4 | | | | V |
| | (I _{OH} = -6 mA) | 3.84 | | 3.84 | | | | V |
| | (I _{OH} = -4 mA) | | | | | 3.7 | | V |
| V _{OL} ¹ | (I _{OL} = 10 mA) ² | | 0.5 | | 0.5 | | | V |
| | (I _{OL} = 6 mA) | | 0.33 | | 0.33 | 0.40 | | V |
| V _{IL} | | -0.3 | 0.8 | -0.3 | 0.8 | -0.3 | 0.8 | V |
| V _{IH} | | 2.0 | V _{CC} + 0.3 | 2.0 | V _{CC} + 0.3 | 2.0 | V _{CC} + 0.3 | V |
| Input Transition Time t _R , t _F ² | | | 500 | | 500 | | 500 | ns |
| C _{IO} I/O Capacitance ^{2, 3} | | | 10 | | 10 | | 10 | pF |
| Standby Current, I _{CC} ⁴ (typical = 1 mA) | | | 2.0 | | 20.0 | | 5.0 | mA |
| I _{CC(D)} Dynamic V _{CC} Supply Current | | See "Power Dissipation" on page 15. | | | | | | |
| Low Power Mode Standby Current, I _{CC} | | | 0.5 | | 10.0 | | 2.0 | mA |

Notes:

- Only one output tested at a time. V_{CC} = min.
- Not tested, for information only.
- Includes worst-case 84-Pin CPGA package capacitance. V_{OUT} = 0 V, f = 1 MHz.
- All outputs unloaded. All inputs = V_{CC} or GND; typical I_{CC} = 0.5 mA. I_{CC} limit includes I_{PP} and I_{SV} during normal operation.

3.3V Operating Conditions

Absolute Maximum Ratings

Free Air Temperature Range

| Symbol | Parameter | Limits | Units |
|-----------|--------------------------------------|------------------------|-------|
| V_{CC} | DC Supply Voltage | -0.5 to +7.0 | V |
| V_I | Input Voltage | -0.5 to $V_{CC} + 0.5$ | V |
| V_O | Output Voltage | -0.5 to $V_{CC} + 0.5$ | V |
| I_{IO} | I/O Source Sink Current ² | ±20 | mA |
| T_{STG} | Storage Temperature | -65 to +150 | °C |

Notes:

- Stresses beyond those listed under "Absolute Maximum Ratings" may cause permanent damage to the device. Exposure to absolute maximum rated conditions for extended periods may affect device reliability. Device should not be operated outside the Recommended Operating Conditions.
- Device inputs are normally high impedance and draw extremely low current. However, when input voltage is greater than $V_{CC} + 0.5V$ or less than $GND - 0.5V$, the internal protection diodes will forward-bias and can draw excessive current.

Recommended Operating Conditions

| Parameter | Commercial | Industrial | Units |
|--------------------------------|------------|------------|-------|
| Temperature Range ¹ | 0 to +70 | 40 to +85 | °C |
| Power Supply Tolerance | ±5 | ±10 | %V |
| V_{CCI} | 3.0 to 3.6 | 3.0 to 3.6 | V |
| V_{CCA} | 3.0 to 3.6 | 3.0 to 3.6 | V |

Note:

- Ambient temperature (T_A) is used for commercial.

Electrical Specifications

| Parameter | Commercial | | Industrial | | Units |
|--|-------------------------------------|----------------|------------|----------------|-------|
| | Min. | Max. | Min. | Max. | |
| V_{OH}^1 | $(I_{OH} = -4 \text{ mA})$ | | 3.7 | | V |
| | $(I_{OH} = -3.2 \text{ mA})$ | | | | V |
| V_{OL}^1 | $(I_{OL} = 6 \text{ mA})$ | | 0.48 | | V |
| V_{IL} | -0.3 | 0.8 | -0.3 | 0.8 | V |
| V_{IH} | 2.0 | $V_{CC} + 0.3$ | 2.0 | $V_{CC} + 0.3$ | V |
| Input Transition Time t_R, t_F^2 | 500 | | 500 | | ns |
| C_{IO} I/O Capacitance ^{2,3} | 10 | | 10 | | pF |
| Standby Current, I_{CC}^4 (typical = 0.3 mA) | 2.0 | | 5.0 | | mA |
| $I_{CC(D)}$ Dynamic V_{CC} Supply Current | See "Power Dissipation" on page 15. | | | | |
| Low Power Mode Standby Current, I_{CC} | 0.5 | | 2.0 | | mA |

Notes:

- Only one output tested at a time. $V_{CC} = \text{min.}$
- Not tested, for information only.
- Includes worst-case 84-Pin PLCC package capacitance. $V_{OUT} = 0V, f = 1 \text{ MHz.}$
- Typical standby current = 0.5 mA. All outputs unloaded. All inputs = V_{CC} or $GND.$

Package Thermal Characteristics

The device junction-to-case thermal characteristic is θ_{jc} and the junction-to-ambient air characteristic is θ_{ja} . The thermal characteristics for θ_{ja} are shown with two different air flow rates.

Maximum junction temperature is 150 C.

A sample calculation of the absolute maximum power dissipation allowed for a PQFP 160-pin package at commercial temperature is as follows:

$$\frac{\text{Max. junction temp. (}^\circ\text{C)} - \text{Max. commercial temp.}}{\theta_{ja} \text{ (}^\circ\text{C/W)}} = \frac{150^\circ\text{C} - 70^\circ\text{C}}{30^\circ\text{C/W}} = 2.6\text{W}$$

| Package Type | Pin Count | θ_{ja} | | Maximum Power Dissipation | |
|----------------------------------|-----------|---------------|------------|---------------------------|------------|
| | | Still Air | 300 ft/min | Still Air | 300 ft/min |
| Plastic Quad Flat Pack | 100 | 42°C/W | 33°C/W | 1.9 W | 2.4 W |
| Plastic Quad Flat Pack | 160 | 34°C/W | 27°C/W | 2.4 W | 3.0 W |
| Plastic Quad Flat Pack | 208 | 25°C/W | 16.2°C/W | 3.2 W | 4.9 W |
| Plastic Leaded Chip Carrier | 44 | 45°C/W | 35°C/W | 1.8 W | 2.3 W |
| Plastic Leaded Chip Carrier | 68 | 38°C/W | 29°C/W | 2.1 W | 2.8 W |
| Plastic Leaded Chip Carrier | 84 | 37°C/W | 28°C/W | 2.2 W | 2.9 W |
| Thin Plastic Quad Flat Pack | 176 | 32°C/W | 25°C/W | 2.5 W | 3.2 W |
| Very Thin Plastic Quad Flat Pack | 80 | 43°C/W | 35°C/W | 1.9 W | 2.3 W |
| Very Thin Plastic Quad Flat Pack | 100 | 43°C/W | 35°C/W | 1.9 W | 2.3 W |
| Power Quad Flat Pack | 208 | 16.8°C/W | 11.4°C/W | 4.8 W | 7.0 W |
| Power Quad Flat Pack | 240 | 16.1°C/W | 10.6°C/W | 5.0 W | 7.5 W |

Power Dissipation

General Power Equation

$$P = [I_{CC\text{standby}} + I_{CC\text{active}}] * V_{CC} + I_{OL} * V_{OL} * N + I_{OH} * (V_{CC} - V_{OH}) * M$$

where:

$I_{CC\text{standby}}$ is the current flowing when no inputs or outputs are changing.

$I_{CC\text{active}}$ is the current flowing due to CMOS switching.

I_{OL} , I_{OH} are TTL sink/source currents.

V_{OL} , V_{OH} are TTL level output voltages.

N equals the number of outputs driving TTL loads to V_{OL} .

M equals the number of outputs driving TTL loads to V_{OH} .

An accurate determination of N and M is problematic because their values depend on the family type, on design details, and on the system I/O. The power can be divided into two components: static and active.

Static Power Component

Actel FPGAs have small static power components that result in power dissipation lower than PALs or PLDs. By integrating multiple PALs/PLDs into one FPGA, an even greater reduction in board-level power dissipation can be achieved.

The power due to standby current is typically a small component of the overall power. Standby power is calculated for commercial, worst-case conditions:

| | | |
|----------|----------|---------|
| I_{CC} | V_{CC} | Power |
| 2 mA | 5.25 V | 10.5 mW |

The static power dissipation by TTL loads depends on the number of outputs driving HIGH or LOW, and on the DC load current. Again, this number is typically small. For instance, a 32-bit bus sinking 4 mA at 0.33V will generate 42 mW with all outputs driving LOW, and 140 mW with all outputs driving HIGH. The actual dissipation will average somewhere in between, as I/Os switch states with time.

Active Power Component

Power dissipation in CMOS devices is usually dominated by the active (dynamic) power dissipation. This component is frequency-dependent, a function of the logic and the external I/O. Active power dissipation results from charging internal chip capacitances of the interconnect, unprogrammed antifuses, module inputs, and module outputs, plus external capacitance due to PC board traces and load device inputs. An additional component of the active power dissipation is the totem pole current in the CMOS transistor pairs. The net effect can be associated with an equivalent capacitance that can be combined with frequency and voltage to represent active power dissipation.

Equivalent Capacitance

The power dissipated by a CMOS circuit can be expressed by Equation 1.

$$\text{Power (W)} = C_{EQ} * V_{CC}^2 * F \quad (1)$$

where:

C_{EQ} is the equivalent capacitance expressed in picofarads (pF).

V_{CC} is power supply in volts (V).

F is the switching frequency in megahertz (MHz).

Equivalent capacitance is calculated by measuring $I_{CC\text{active}}$ at a specified frequency and voltage for each circuit component of interest. Measurements have been made over a range of frequencies at a fixed value of V_{CC} . Equivalent capacitance is frequency-independent, so the results can be used over a wide range of operating conditions. Equivalent capacitance values are shown below.

C_{EQ} Values for Actel FPGAs

| | |
|--|------|
| Modules (C_{EQM}) | 3.5 |
| Input Buffers (C_{EQI}) | 11.6 |
| Output Buffers (C_{EQO}) | 22.0 |
| Routed Array Clock Buffer Loads (C_{EQCR}) | 3.5 |

To calculate the active power dissipated from the complete design, the switching frequency of each part of the logic must be known. Equation 2 shows a piece-wise linear summation over all components.

$$\begin{aligned} \text{Power} = & V_{CC}^2 * [(m * C_{EQM} * f_m)_{\text{Modules}} + \\ & (n * C_{EQI} * f_n)_{\text{Inputs}} + (p * (C_{EQO} + C_L) * f_p)_{\text{Outputs}} + \\ & 0.5 * (q_1 * C_{EQCR} * f_{q1})_{\text{routed_Clk1}} + (r_1 * f_{q1})_{\text{routed_Clk1}} + \\ & 0.5 * (q_2 * C_{EQCR} * f_{q2})_{\text{routed_Clk2}} + (r_2 * f_{q2})_{\text{routed_Clk2}} \quad (2) \end{aligned}$$

where:

- m = Number of logic modules switching at frequency f_m
- n = Number of input buffers switching at frequency f_n
- p = Number of output buffers switching at frequency f_p
- q_1 = Number of clock loads on the first routed array clock
- q_2 = Number of clock loads on the second routed array clock
- r_1 = Fixed capacitance due to first routed array clock
- r_2 = Fixed capacitance due to second routed array clock
- C_{EQM} = Equivalent capacitance of logic modules in pF
- C_{EQI} = Equivalent capacitance of input buffers in pF
- C_{EQO} = Equivalent capacitance of output buffers in pF
- C_{EQCR} = Equivalent capacitance of routed array clock in pF
- C_L = Output load capacitance in pF

- f_m = Average logic module switching rate in MHz
- f_n = Average input buffer switching rate in MHz
- f_p = Average output buffer switching rate in MHz
- f_{q1} = Average first routed array clock rate in MHz
- f_{q2} = Average second routed array clock rate in MHz

Fixed Capacitance Values for Actel FPGAs (pF)

| Device Type | r_1 routed_Clk1 | r_2 routed_Clk2 |
|-------------|----------------------|----------------------|
| A40M X02 | 41.4 | N/A |
| A40M X04 | 68.6 | N/A |
| A40M X09 | 134 | 134 |
| A42M X16 | 168 | 168 |
| A42M X24 | 190 | 190 |
| A42M X36 | 230 | 230 |
| A42M X52 | 285 | 285 |

Determining Average Switching Frequency

To determine the switching frequency for a design, you must have a detailed understanding of the data input values to the circuit. The following guidelines represent worst-case scenarios; these can be used to generally predict the upper limits of power dissipation.

- Logic Modules (m) = 80% of Combinatorial Modules
- Inputs Switching (n) = #of Inputs/4
- Outputs Switching (p) = #Outputs/4
- First Routed Array Clock Loads (q_1) = 40% of Sequential Modules
- Second Routed Array Clock Loads (q_2) = 40% of Sequential Modules
- Load Capacitance (C_L) = 35 pF
- Average Logic Module Switching Rate (f_m) = $F/10$
- Average Input Switching Rate (f_n) = $F/5$
- Average Output Switching Rate (f_p) = $F/10$
- Average First Routed Array Clock Rate (f_{q1}) = F
- Average Second Routed Array Clock Rate (f_{q2}) = $F/2$

40MX Timing Model*

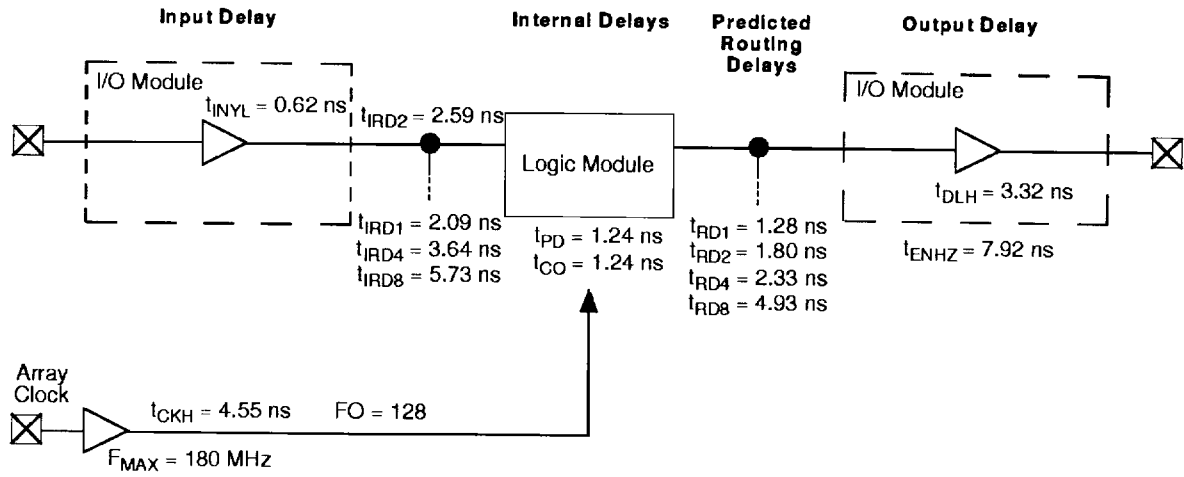

* Values are shown for 40MX-3 speed devices at 5.0V worst-case commercial conditions.

42MX Timing Model*

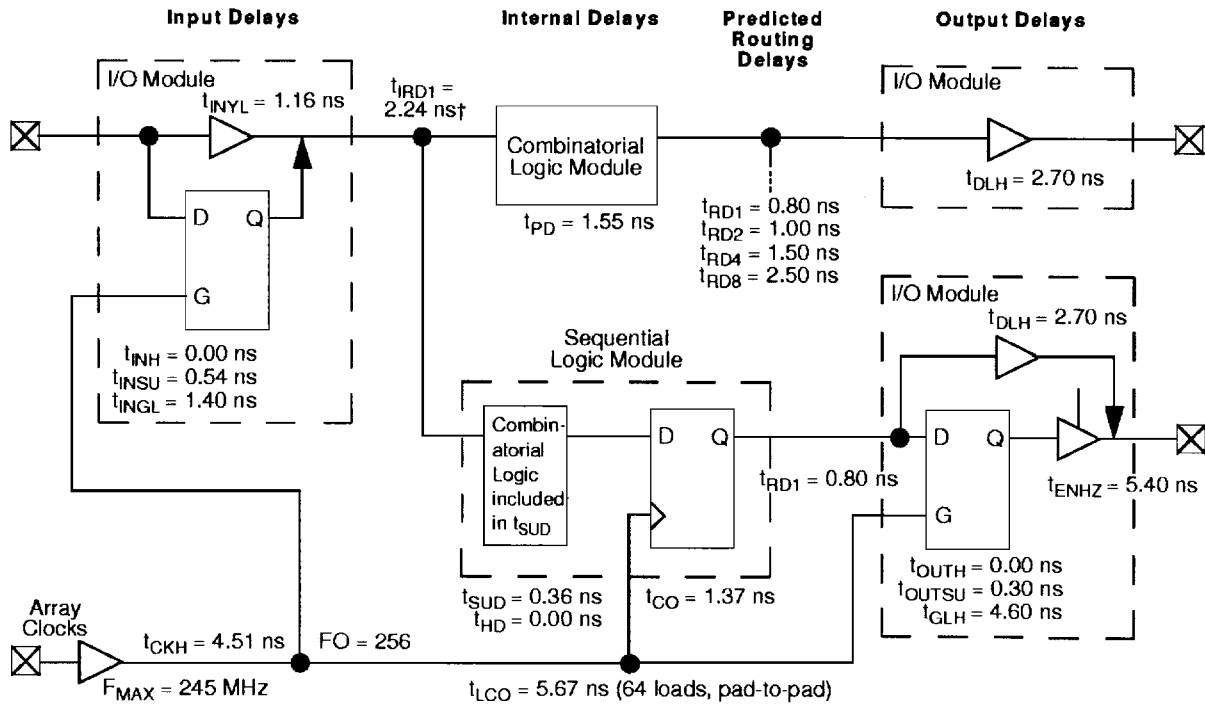

*Values are shown for A42MXD9-2 at 5.0V worst-case commercial conditions

† Input module predicted routing delay

42MX Timing Model (Logic Functions using Quadrant Clocks)*

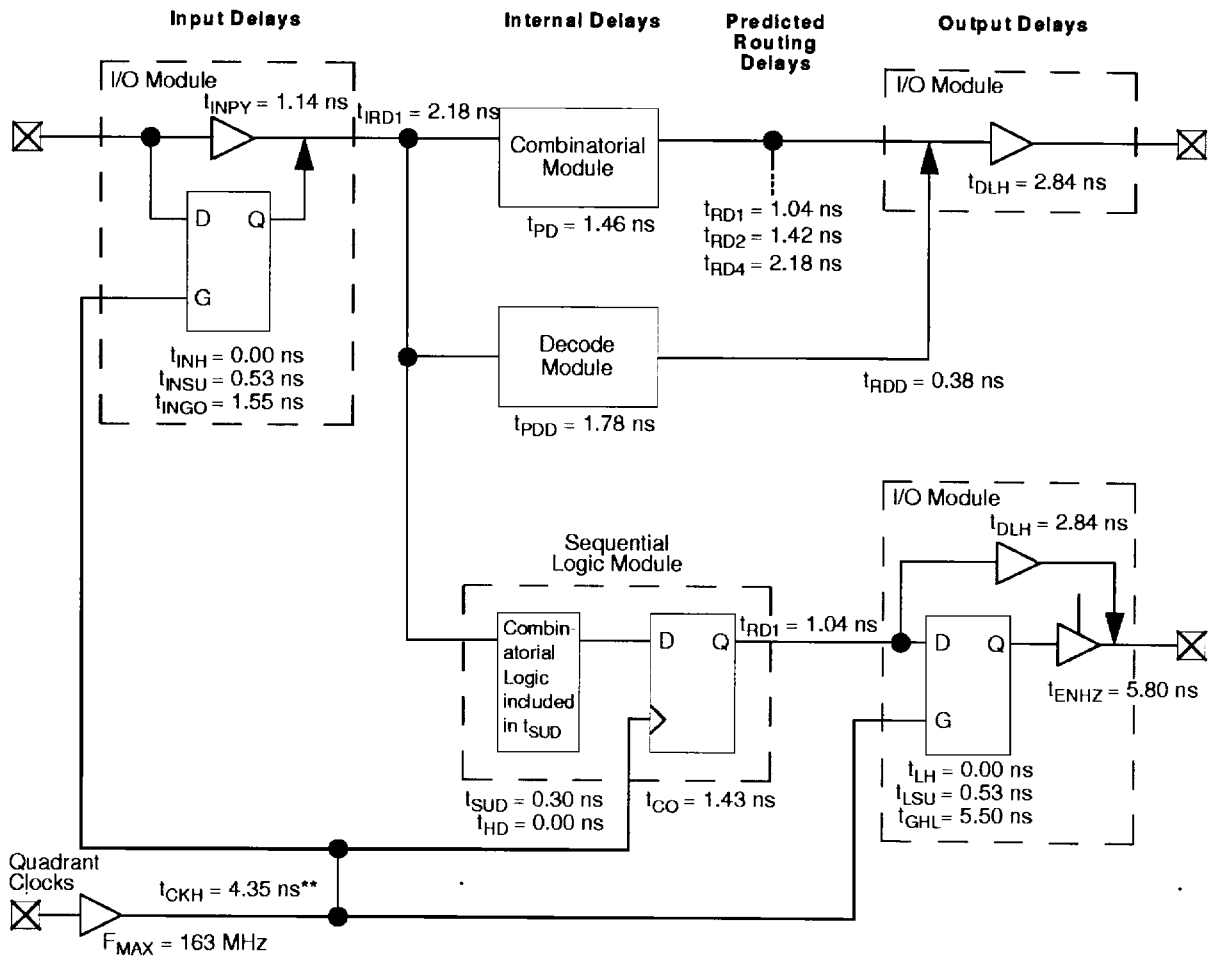

* Preliminary values are shown for A42MX36-2 at 5.0V worst-case commercial conditions

** Load-dependent

42MX Timing Model (SRAM Functions)*

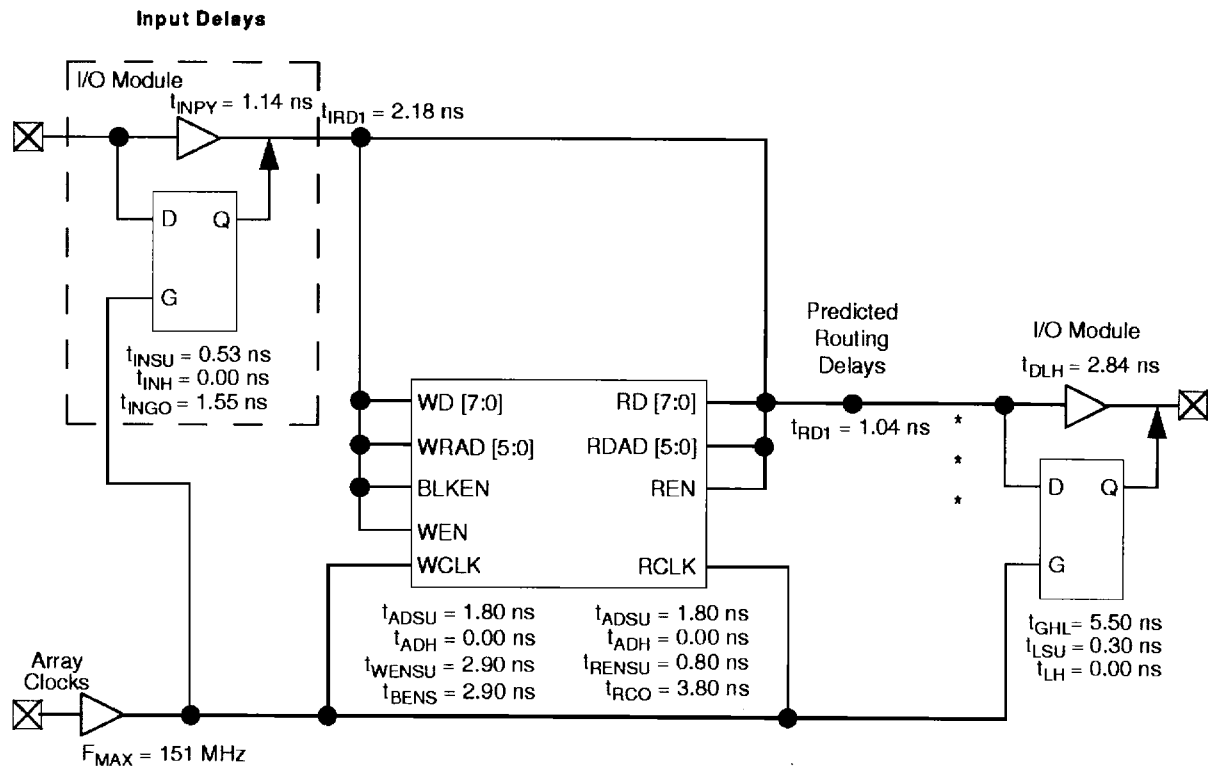

*Values are shown for A42MX36-2 at 5.0V worst-case commercial conditions.

Parameter Measurement

Output Buffer Delays

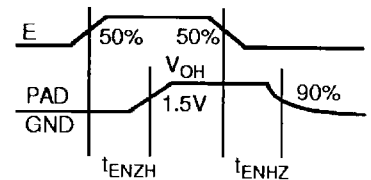
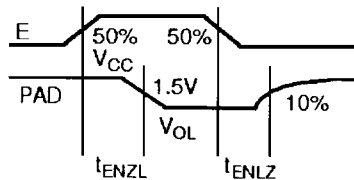
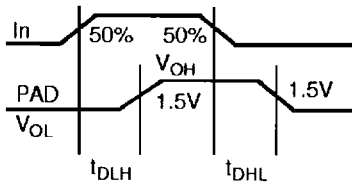

AC Test Loads

Load 1
(Used to measure propagation delay)

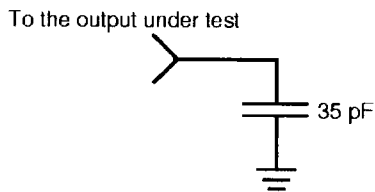

Load 2
(Used to measure rising/falling edges)

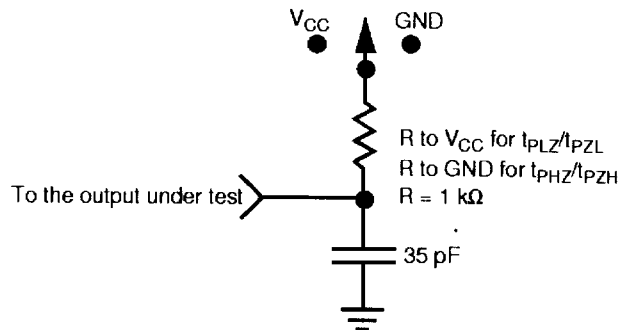

Input Buffer Delays

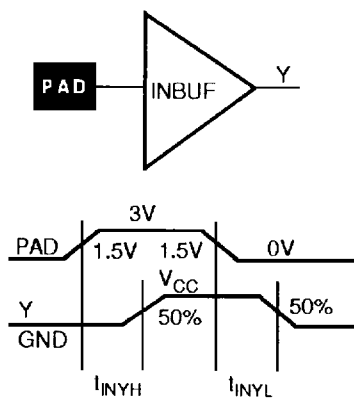

Module Delays

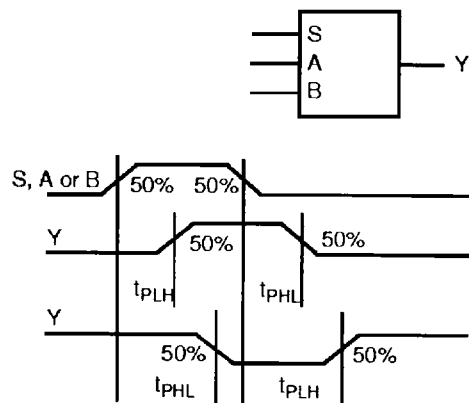

Sequential Module Timing Characteristics

Flip-Flops and Latches

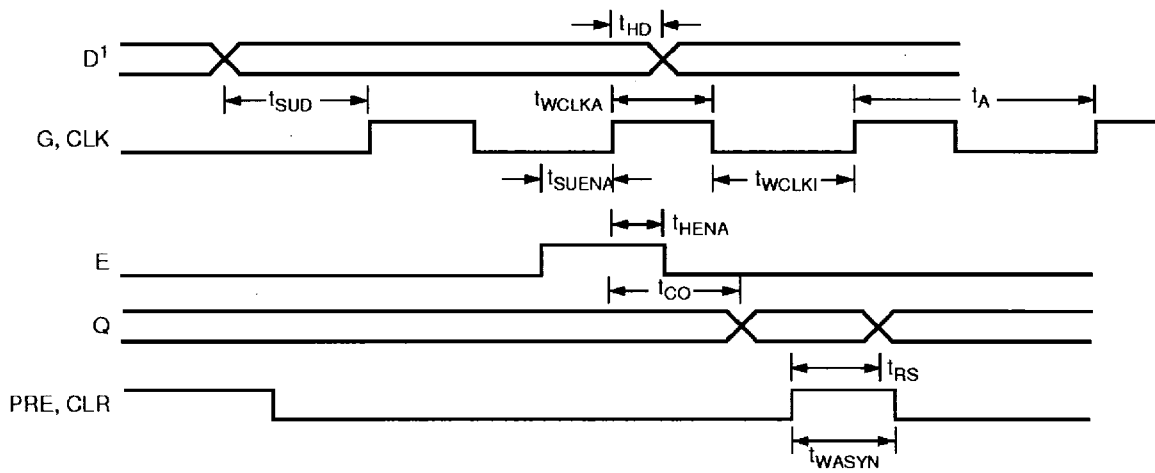
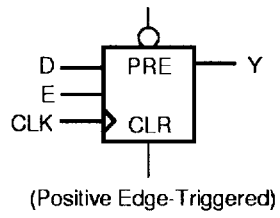

Note: D represents all data functions involving A, B, and S for multiplexed flip-flops.

Sequential Timing Characteristics (continued)

Input Buffer Latches

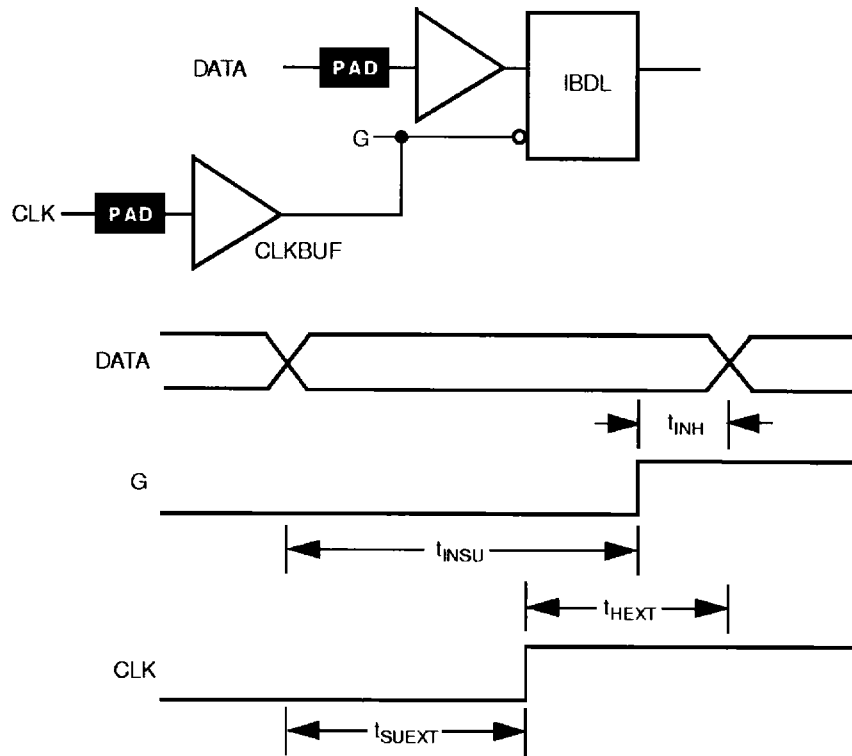

Output Buffer Latches

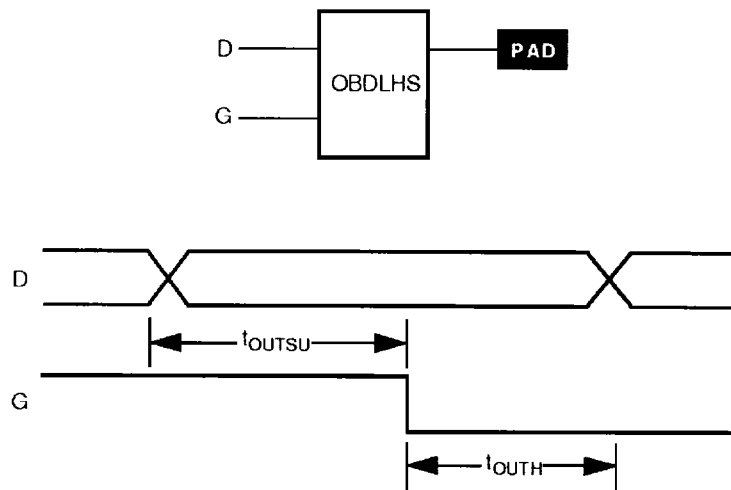

Decode Module Timing

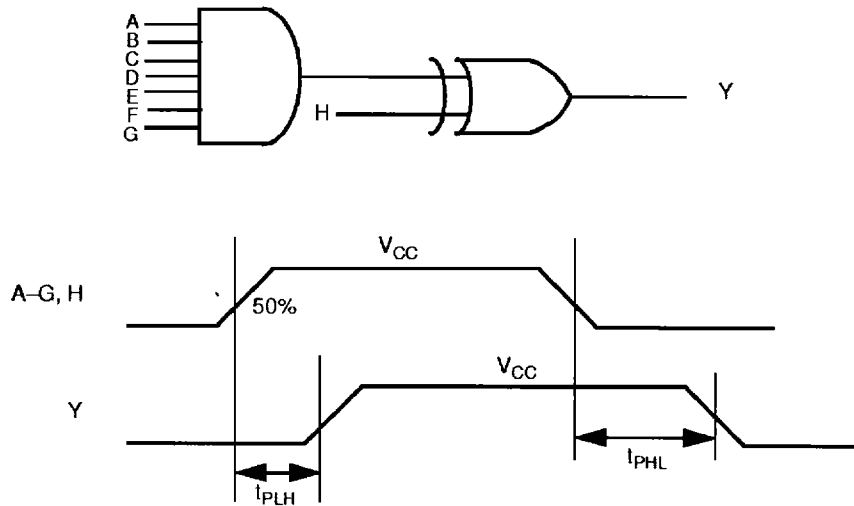

SRAM Timing Characteristics

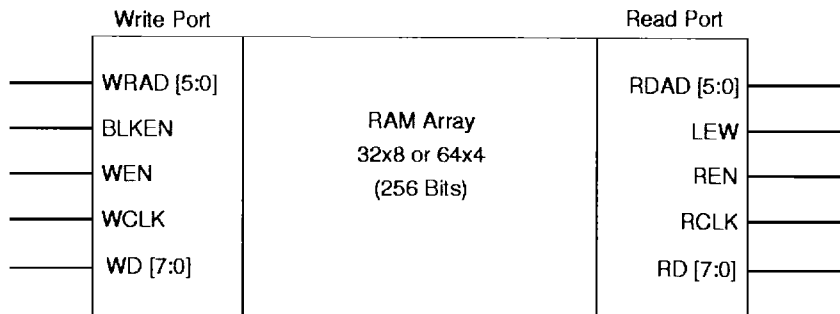

Dual-Port SRAM Timing Waveforms

42MX SRAM Write Operation.

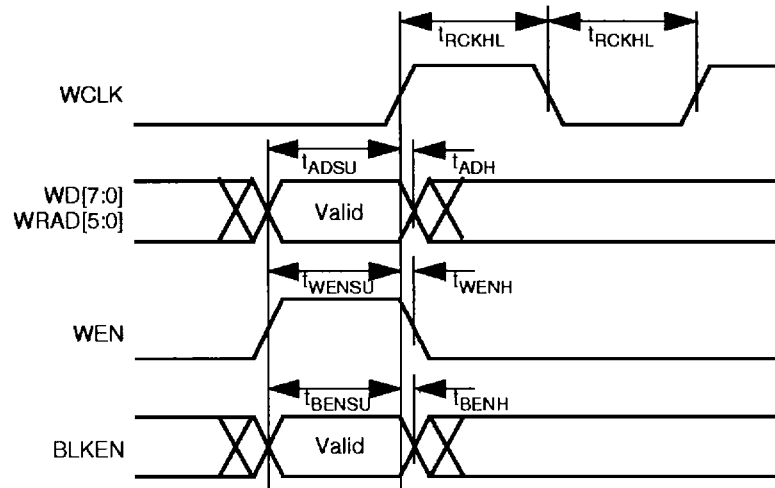

Note: Identical timing for falling edge clock.

42MX SRAM Synchronous Read Operation

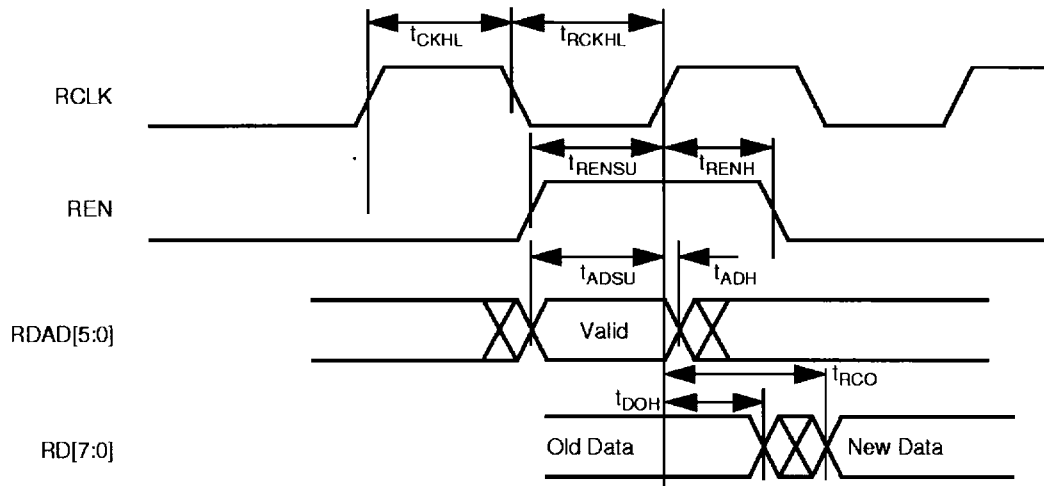

Note: Identical timing for falling edge clock.

42MX SRAM Asynchronous Read Operation—Type 1

(Read Address Controlled)

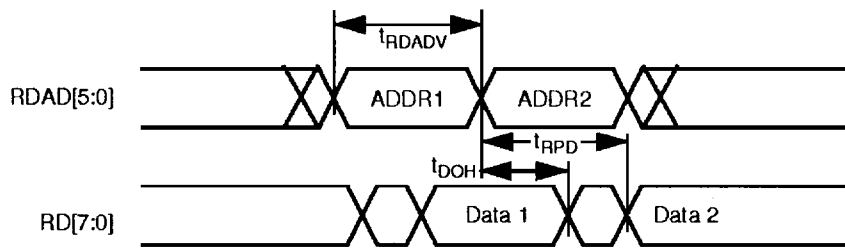

42MX SRAM Asynchronous Read Operation—Type 2

(Write Address Controlled)

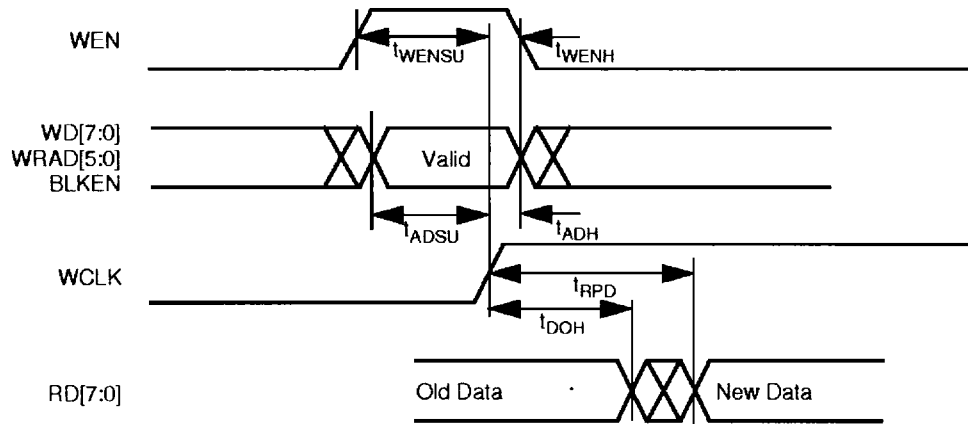

**Predictable Performance:
Tight Delay Distributions**

Propagation delay between logic modules depends on the resistive and capacitive loading of the routing tracks, the interconnect elements, and the module inputs being driven. Propagation delay increases as the length of routing tracks, the number of interconnect elements, or the number of inputs increases.

From a design perspective, the propagation delay can be statistically correlated or modeled by the fanout (number of loads) driven by a module. Higher fanout usually requires some paths to have longer routing tracks.

The MX FPGAs deliver a tight fanout delay distribution. This tight distribution is achieved in two ways: by decreasing the delay of the interconnect elements and by decreasing the number of interconnect elements per path.

Actel's patented PLICE antifuse offers an very low resistive/capacitive interconnect. The antifuses, fabricated in 0.45 micron lithography, offer nominal levels of 100 ohms resistance and 7.0 femtofarad (fF) capacitance per antifuse.

The Integrator Series fanout distribution is also tight due to the low number of antifuses required for each interconnect path. The proprietary architecture limits the number of antifuses per path to a maximum of four, with 90% of interconnects using two antifuses.

Timing Characteristics

Timing characteristics for devices fall into three categories: family-dependent, device-dependent, and design-dependent. The input and output buffer characteristics are common to all Integrator Series members. Internal routing delays are device-dependent. Design dependency means actual delays

are not determined until after place and route of the user's design is complete. Delay values may then be determined by using the Designer Series utility or by performing simulation with post-layout delays.

Critical Nets and Typical Nets

Propagation delays in this data sheet apply to typical nets. The abundant routing resources in the MX architecture allows for deterministic timing using Actel's Designer Series development tools which include DirectTime, a timing-driven place-and-route tool. Using DirectTime, the designer can specify timing-critical nets and system clock frequency. Using these timing specifications, the place-and-route software optimizes the layout of the design to meet the user's specifications.

Long Tracks

Some nets in the design use long tracks which are special routing resources that span multiple rows, columns, or modules. Long tracks employ three and sometimes four antifuse connections, which increase capacitance and resistance, resulting in longer net delays for macros connected to long tracks. Typically, up to 6% of nets in a fully utilized device require long tracks. Long tracks add approximately 3 ns to 6 ns delay, which is represented statistically in higher fanout (FO=8) routing delays in the data sheet specifications section.

Timing Derating

A timing derating factor of 0.45 is used to reflect best-case processing. Note that this factor is relative to the standard speed timing parameters, and must be multiplied by the appropriate voltage and temperature derating factors for a given application.

Timing Derating Factor (Temperature and Voltage)

| | Industrial | |
|------------------------------|------------|------|
| | Min. | Max. |
| (Commercial Specification) x | 0.69 | 1.11 |

Timing Derating Factor for Designs at Typical Temperature (T_j = 25°C) and Voltage (5.0V)

T_j = 25°C

| | |
|---|------|
| (Maximum Specification, Worst-Case Condition) x | 0.85 |
|---|------|

Note: This derating factor applies to all routing and propagation delays.

Temperature and Voltage Derating Factors
 (Normalized to Worst-Case Commercial, T_J = 4.75V, 70°C)

$V_J = 4.75V, 70^\circ C$

| | -55 | -40 | 0 | 25 | 70 | 85 | 125 |
|------|------|------|------|------|------|------|------|
| 4.50 | 0.75 | 0.79 | 0.86 | 0.92 | 1.06 | 1.11 | 1.23 |
| 4.75 | 0.71 | 0.75 | 0.82 | 0.87 | 1.00 | 1.05 | 1.16 |
| 5.00 | 0.69 | 0.72 | 0.80 | 0.85 | 0.97 | 1.02 | 1.13 |
| 5.25 | 0.68 | 0.69 | 0.77 | 0.82 | 0.95 | 0.98 | 1.09 |
| 5.50 | 0.67 | 0.69 | 0.76 | 0.81 | 0.93 | 0.97 | 1.08 |

Junction Temperature and Voltage Derating Curves
 (Normalized to Worst-Case Commercial, T_J = 4.75V, 70°C)

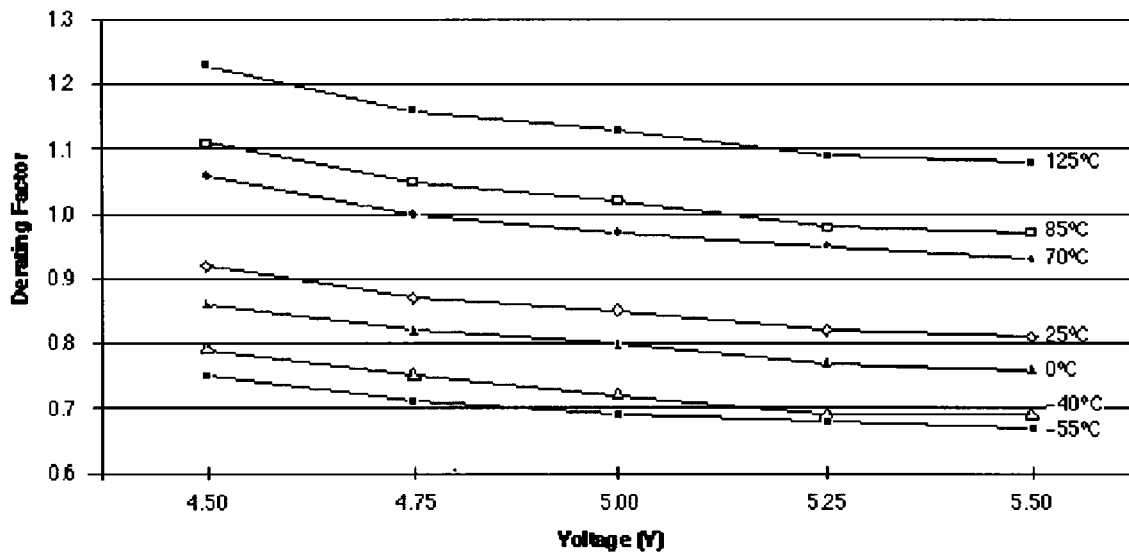

Note: This derating factor applies to all routing and propagation delays.

A40MX02 Timing Characteristics (Nominal 5.0V Operation)

(Worst-Case Commercial Conditions, $V_{CC} = 4.75V$, $T_J = 70^\circ C$)

| Logic Module Propagation Delays | | '-3' Speed | | '-2' Speed | | '-1' Speed | | 'Std' Speed | | '-F' Speed | | |
|---|--|------------|--------|------------|--------|------------|--------|-------------|--------|------------|-------|-------|
| Parameter | Description | Min. | Max. | Min. | Max. | Min. | Max. | Min. | Max. | Min. | Max. | Units |
| t_{PD1} | Single Module | | 1.24 | | 1.43 | | 1.63 | | 1.90 | | 2.66 | ns |
| t_{PD2} | Dual-Module Macros | | 2.65 | | 3.06 | | 3.47 | | 4.08 | | 5.71 | ns |
| t_{CO} | Sequential Clock-to-Q | | 1.24 | | 1.43 | | 1.62 | | 1.90 | | 2.66 | ns |
| t_{GO} | Latch G-to-Q | | 1.24 | | 1.43 | | 1.62 | | 1.90 | | 2.66 | ns |
| t_{RS} | Flip-Flop (Latch) Reset-to-Q | | 1.24 | | 1.43 | | 1.62 | | 1.90 | | 2.66 | ns |
| Predicted Routing Delays¹ | | | | | | | | | | | | |
| t_{RD1} | FO=1 Routing Delay | | 1.28 | | 1.48 | | 1.67 | | 1.97 | | 2.76 | ns |
| t_{RD2} | FO=2 Routing Delay | | 1.80 | | 2.08 | | 2.35 | | 2.77 | | 3.88 | ns |
| t_{RD3} | FO=3 Routing Delay | | 2.33 | | 2.69 | | 3.04 | | 3.58 | | 5.01 | ns |
| t_{RD4} | FO=4 Routing Delay | | 2.85 | | 3.29 | | 3.72 | | 4.38 | | 6.13 | ns |
| t_{RD8} | FO=8 Routing Delay | | 4.93 | | 5.69 | | 6.45 | | 7.59 | | 10.63 | ns |
| Sequential Timing Characteristics | | | | | | | | | | | | |
| t_{SUD}^2 | Flip-Flop (Latch) Data Input Set-Up | 3.06 | | 3.53 | | 4.00 | | 4.70 | | 6.58 | | ns |
| t_{HD}^3 | Flip-Flop (Latch) Data Input Hold | 0.00 | | 0.00 | | 0.00 | | 0.00 | | 0.00 | | ns |
| t_{SUENA} | Flip-Flop (Latch) Enable Set-Up | 3.06 | | 3.53 | | 4.00 | | 4.70 | | 6.58 | | ns |
| t_{HENA} | Flip-Flop (Latch) Enable Hold | 0.00 | | 0.00 | | 0.00 | | 0.00 | | 0.00 | | ns |
| t_{WCLKA} | Flip-Flop (Latch) Clock Active Pulse Width | 3.25 | | 3.75 | | 4.25 | | 5.00 | | 7.00 | | ns |
| t_{WASYN} | Flip-Flop (Latch) Asynchronous Pulse Width | 3.25 | | 3.75 | | 4.25 | | 5.00 | | 7.00 | | ns |
| t_A | Flip-Flop Clock Input Period | 4.84 | | 5.59 | | 6.33 | | 7.45 | | 10.43 | | ns |
| f_{MAX} | Flip-Flop (Latch) Clock Frequency (FO = 128) | | 180.90 | | 167.50 | | 154.10 | | 134.00 | | 80.40 | MHz |

Notes:

1. Routing delays are for typical designs across worst-case operating conditions. These parameters should be used for estimating device performance. Post-route timing analysis or simulation is required to determine actual worst-case performance. Post-route timing is based on actual routing delay measurements performed on the device prior to shipment.
2. Set-up times assume fanout of 3. Further testing information can be obtained from the DirectTime Analyzer utility.
3. The hold time for the DFME1A macro may be greater than 0 ns. Use the Designer 3.0 or later DirectTime Analyzer to check the hold time for this macro.



A40MX02 Timing Characteristics (Nominal 5.0V Operation)

(continued)

(Worst-Case Commercial Conditions)

| Input Module Propagation Delays | | | '-3' Speed | | '-2' Speed | | '-1' Speed | | 'Std' Speed | | '-F' Speed | | |
|--|--------------------------|----------|------------|--------|------------|--------|------------|--------|-------------|--------|------------|-------|-------|
| Parameter | Description | | Min. | Max. | Min. | Max. | Min. | Max. | Min. | Max. | Min. | Max. | Units |
| t _{INYH} | Pad-to-Y HIGH | | | 0.70 | | 0.80 | | 0.91 | | 1.07 | | 1.50 | ns |
| t _{INYL} | Pad-to-Y LOW | | | 0.62 | | 0.71 | | 0.81 | | 0.95 | | 1.33 | ns |
| Input Module Predicted Routing Delays ¹ | | | | | | | | | | | | | |
| t _{IRD1} | FO=1 Routing Delay | | | 2.07 | | 2.39 | | 2.17 | | 3.19 | | 4.47 | ns |
| t _{IRD2} | FO=2 Routing Delay | | | 2.59 | | 2.99 | | 3.39 | | 3.99 | | 5.59 | ns |
| t _{IRD3} | FO=3 Routing Delay | | | 3.12 | | 3.60 | | 4.08 | | 4.80 | | 6.72 | ns |
| t _{IRD4} | FO=4 Routing Delay | | | 3.64 | | 4.20 | | 4.76 | | 5.60 | | 7.84 | ns |
| t _{IRD8} | FO=8 Routing Delay | | | 5.73 | | 6.62 | | 7.50 | | 8.82 | | 12.35 | ns |
| Global Clock Network | | | | | | | | | | | | | |
| t _{CKH} | Input Low to HIGH | FO = 16 | | 4.55 | | 5.25 | | 5.95 | | 7.00 | | 9.80 | ns |
| | | FO = 128 | | 4.55 | | 5.25 | | 5.95 | | 7.00 | | 9.80 | |
| t _{CKL} | Input High to LOW | FO = 16 | | 4.81 | | 5.55 | | 6.29 | | 7.40 | | 10.36 | ns |
| | | FO = 128 | | 4.81 | | 5.55 | | 6.29 | | 7.40 | | 10.36 | |
| t _{PWH} | Minimum Pulse Width HIGH | FO = 16 | 2.24 | | 2.58 | | 2.92 | | 3.44 | | 4.82 | ns | |
| | | FO = 128 | 2.35 | | 2.71 | | 3.07 | | 3.61 | | 5.05 | | |
| t _{PWL} | Minimum Pulse Width LOW | FO = 16 | 2.24 | | 2.58 | | 2.92 | | 3.44 | | 4.82 | ns | |
| | | FO = 128 | 2.35 | | 2.71 | | 3.07 | | 3.61 | | 5.05 | | |
| t _{CKSW} | Maximum Skew | FO = 16 | | 0.39 | | 0.45 | | 0.51 | | 0.60 | | 0.84 | ns |
| | | FO = 128 | | 0.53 | | 0.62 | | 0.70 | | 0.82 | | 1.15 | |
| t _P | Minimum Period | FO = 16 | 4.67 | | 5.39 | | 6.10 | | 7.18 | | 10.05 | ns | |
| | | FO = 128 | 4.84 | | 5.59 | | 6.33 | | 7.45 | | 10.43 | | |
| f _{MAX} | Maximum Frequency | FO = 16 | | 187.60 | | 174.79 | | 159.85 | | 139.00 | | 83.40 | MHz |
| | | FO = 128 | | 180.90 | | 167.50 | | 154.10 | | 134.00 | | 80.40 | |

Note:

- These parameters should be used for estimating device performance. Optimization techniques may further reduce delays by 0 to 4 ns. Routing delays are for typical designs across worst-case operating conditions. Post-route timing analysis or simulation is required to determine actual worst-case performance. Post-route timing is based on actual routing delay measurements performed on the device prior to shipment.

A40MX02 Timing Characteristics (Nominal 5.0V Operation)

(continued)

(Worst-Case Commercial Conditions)

| Output Module Timing | | '-3' Speed | | '-2' Speed | | '-1' Speed | | 'Std' Speed | | '-F' Speed | | |
|--|----------------------|------------|------|------------|------|------------|-------|-------------|-------|------------|-------|-------|
| Parameter | Description | Min. | Max. | Min. | Max. | Min. | Max. | Min. | Max. | Min. | Max. | Units |
| TTL Output Module Timing¹ | | | | | | | | | | | | |
| t _{DLH} | Data-to-Pad HIGH | | 3.32 | | 3.83 | | 4.34 | | 5.11 | | 7.15 | ns |
| t _{DHL} | Data-to-Pad LOW | | 3.98 | | 4.60 | | 5.21 | | 6.13 | | 8.58 | ns |
| t _{ENZH} | Enable Pad Z to HIGH | | 3.74 | | 4.31 | | 4.89 | | 5.75 | | 8.05 | ns |
| t _{ENZL} | Enable Pad Z to LOW | | 4.69 | | 5.41 | | 6.13 | | 7.21 | | 10.09 | ns |
| t _{ENHZ} | Enable Pad HIGH to Z | | 7.92 | | 9.14 | | 10.35 | | 12.18 | | 17.05 | ns |
| t _{ENLZ} | Enable Pad LOW to Z | | 5.86 | | 6.77 | | 7.67 | | 9.02 | | 12.63 | ns |
| d _{TLH} | Delta LOW to HIGH | | 0.02 | | 0.02 | | 0.03 | | 0.03 | | 0.04 | ns/pF |
| d _{THL} | Delta HIGH to LOW | | 0.03 | | 0.03 | | 0.03 | | 0.04 | | 0.06 | ns/pF |
| CMOS Output Module Timing¹ | | | | | | | | | | | | |
| t _{DLH} | Data-to-Pad HIGH | | 3.93 | | 4.54 | | 5.14 | | 6.05 | | 8.47 | ns |
| t _{DHL} | Data-to-Pad LOW | | 3.39 | | 3.92 | | 4.44 | | 5.22 | | 7.31 | ns |
| t _{ENZH} | Enable Pad Z to HIGH | | 3.37 | | 3.89 | | 4.41 | | 5.19 | | 7.27 | ns |
| t _{ENZL} | Enable Pad Z to LOW | | 4.88 | | 5.63 | | 6.38 | | 7.51 | | 10.51 | ns |
| t _{ENHZ} | Enable Pad HIGH to Z | | 7.92 | | 9.14 | | 10.35 | | 12.18 | | 17.05 | ns |
| t _{ENLZ} | Enable Pad LOW to Z | | 5.86 | | 6.77 | | 7.67 | | 9.02 | | 12.63 | ns |
| d _{TLH} | Delta LOW to HIGH | | 0.03 | | 0.04 | | 0.04 | | 0.05 | | 0.07 | ns/pF |
| d _{THL} | Delta HIGH to LOW | | 0.02 | | 0.02 | | 0.03 | | 0.03 | | 0.04 | ns/pF |

Notes:

- Delays based on 35 pF loading.



A40MX02 Timing Characteristics (Nominal 3.3V Operation)
(Worst-Case Commercial Conditions, V_{CC} = 3.0V, T_J = 70°C)

| Logic Module Propagation Delays | | '-3' Speed | | '-2' Speed | | '-1' Speed | | 'Std' Speed | | '-F' Speed | | |
|--|--|------------|--------|------------|--------|------------|-------|-------------|-------|------------|-------|-------|
| Parameter | Description | Min. | Max. | Min. | Max. | Min. | Max. | Min. | Max. | Min. | Max. | Units |
| t _{PD1} | Single Module | | 1.73 | | 2.00 | | 2.26 | | 2.66 | | 3.72 | ns |
| t _{PD2} | Dual-Module Macros | | 3.71 | | 4.28 | | 4.86 | | 5.71 | | 8.00 | ns |
| t _{CO} | Sequential Clock-to-Q | | 1.73 | | 2.00 | | 2.26 | | 2.66 | | 3.72 | ns |
| t _{GO} | Latch G-to-Q | | 1.73 | | 2.00 | | 2.26 | | 2.66 | | 3.72 | ns |
| t _{RS} | Flip-Flop (Latch) Reset-to-Q | | 1.73 | | 2.00 | | 2.26 | | 2.66 | | 3.72 | ns |
| Predicted Routing Delays¹ | | | | | | | | | | | | |
| t _{RD1} | FO=1 Routing Delay | | 1.93 | | 2.23 | | 2.52 | | 2.97 | | 4.16 | ns |
| t _{RD2} | FO=2 Routing Delay | | 2.66 | | 3.07 | | 3.47 | | 4.09 | | 5.72 | ns |
| t _{RD3} | FO=3 Routing Delay | | 3.39 | | 3.92 | | 4.44 | | 5.22 | | 7.31 | ns |
| t _{RD4} | FO=4 Routing Delay | | 4.12 | | 4.76 | | 5.39 | | 6.34 | | 8.88 | ns |
| t _{RD8} | FO=8 Routing Delay | | 7.05 | | 8.14 | | 9.22 | | 10.85 | | 15.19 | ns |
| Sequential Timing Characteristics² | | | | | | | | | | | | |
| t _{SUD} | Flip-Flop (Latch) Data Input Set-Up | | 4.28 | | 4.94 | | 5.59 | | 6.58 | | 9.21 | ns |
| t _{HD³} | Flip-Flop (Latch) Data Input Hold | | 0.00 | | 0.00 | | 0.00 | | 0.00 | | 0.00 | ns |
| t _{SUENA} | Flip-Flop (Latch) Enable Set-Up | | 4.28 | | 4.94 | | 5.59 | | 6.58 | | 9.21 | ns |
| t _{HENA} | Flip-Flop (Latch) Enable Hold | | 0.00 | | 0.00 | | 0.00 | | 0.00 | | 0.00 | ns |
| t _{WCLKA} | Flip-Flop (Latch) Clock Active Pulse Width | | 4.55 | | 5.25 | | 5.95 | | 7.00 | | 9.80 | ns |
| t _{WASYN} | Flip-Flop (Latch) Asynchronous Pulse Width | | 4.55 | | 5.25 | | 5.95 | | 7.00 | | 9.80 | ns |
| t _A | Flip-Flop Clock Input Period | | 6.78 | | 7.82 | | 8.87 | | 10.43 | | 14.60 | ns |
| f _{MAX} | Flip-Flop (Latch) Clock Frequency (FO = 128) | | 108.54 | | 100.50 | | 92.46 | | 80.40 | | 48.24 | MHz |

Notes:

1. Routing delays are for typical designs across worst-case operating conditions. These parameters should be used for estimating device performance. Post-route timing analysis or simulation is required to determine actual worst-case performance. Post-route timing is based on actual routing delay measurements performed on the device prior to shipment.
2. Set-up times assume fanout of 3. Further testing information can be obtained from the DirectTime Analyzer utility.
3. The hold time for the DFME1A macro may be greater than 0ns. Use the Designer 3.0 or later DirectTime Analyzer to check the hold time for this macro.

A40MX02 Timing Characteristics (Nominal 3.3V Operation)

(continued)

(Worst-Case Commercial Conditions)

| Input Module Propagation Delays | | | '-3' Speed | | '-2' Speed | | '-1' Speed | | 'Std' Speed | | '-F' Speed | | |
|--|-----------------------------|----------|------------|--------|------------|--------|------------|-------|-------------|-------|------------|-------|-------|
| Parameter Description | | | Min. | Max. | Min. | Max. | Min. | Max. | Min. | Max. | Min. | Max. | Units |
| t _{INYH} | Pad-to-Y HIGH | | | 0.97 | | 1.12 | | 1.27 | | 1.50 | | 2.10 | ns |
| t _{INYL} | Pad-to-Y LOW | | | 0.86 | | 1.00 | | 1.13 | | 1.33 | | 1.86 | ns |
| Input Module Predicted Routing Delays ¹ | | | | | | | | | | | | | |
| t _{IRD1} | FO=1 Routing Delay | | | 2.90 | | 3.35 | | 3.80 | | 4.47 | | 6.25 | ns |
| t _{IRD2} | FO=2 Routing Delay | | | 3.63 | | 4.19 | | 4.75 | | 5.59 | | 7.82 | ns |
| t _{IRD3} | FO=3 Routing Delay | | | 4.37 | | 5.04 | | 5.71 | | 6.72 | | 9.41 | ns |
| t _{IRD4} | FO=4 Routing Delay | | | 5.10 | | 5.88 | | 6.66 | | 7.84 | | 10.98 | ns |
| t _{IRD8} | FO=8 Routing Delay | | | 8.03 | | 9.26 | | 10.50 | | 12.35 | | 17.29 | ns |
| Global Clock Network | | | | | | | | | | | | | |
| t _{CKH} | Input LOW to HIGH | FO = 16 | | 6.37 | | 7.35 | | 8.33 | | 9.80 | | 13.72 | ns |
| | | FO = 128 | | 6.37 | | 7.35 | | 8.33 | | 9.80 | | 13.72 | |
| t _{CKL} | Input HIGH to LOW | FO = 16 | | 6.73 | | 7.77 | | 8.81 | | 10.36 | | 14.50 | ns |
| | | FO = 128 | | 6.73 | | 7.77 | | 8.81 | | 10.36 | | 14.50 | |
| t _{PWH} | Minimum Pulse Width HIGH | FO = 16 | 3.13 | | 3.61 | | 4.09 | | 4.82 | | 6.74 | ns | |
| | | FO = 128 | 3.29 | | 3.79 | | 4.30 | | 5.05 | | 7.08 | | |
| t _{PWL} | Minimum Pulse Width LOW | FO = 16 | 3.13 | | 3.61 | | 4.09 | | 4.82 | | 6.74 | ns | |
| | | FO = 128 | 3.29 | | 3.79 | | 4.30 | | 5.05 | | 7.08 | | |
| t _{CKSW} | Maximum Skew | FO = 16 | | 0.55 | | 0.63 | | 0.71 | | 0.84 | | 1.18 | ns |
| | | FO = 128 | | 0.75 | | 0.86 | | 0.98 | | 1.15 | | 1.61 | |
| t _P | Minimum Period | FO = 16 | 6.53 | | 7.54 | | 8.54 | | 10.05 | | 14.07 | ns | |
| | | FO = 128 | 6.78 | | 7.82 | | 8.87 | | 10.43 | | 14.60 | | |
| f _{MAX} | Maximum Frequency | FO = 16 | | 112.60 | | 104.88 | | 95.91 | | 83.40 | | 50.04 | MHz |
| | | FO = 128 | | 108.54 | | 100.50 | | 92.46 | | 80.40 | | 48.24 | |

Note:

- These parameters should be used for estimating device performance. Optimization techniques may further reduce delays by 0 to 4 ns. Routing delays are for typical designs across worst-case operating conditions. Post-route timing analysis or simulation is required to determine actual worst-case performance. Post-route timing is based on actual routing delay measurements performed on the device prior to shipment.



A40MX02 Timing Characteristics (Nominal 3.3V Operation)

(continued)

(Worst-Case Commercial Conditions)

| Output Module Timing | | '-3' Speed | | '-2' Speed | | '-1' Speed | | 'Std' Speed | | '-F' Speed | | Units |
|--|----------------------|------------|------|------------|------|------------|------|-------------|------|------------|------|-------|
| | | Min. | Max. | Min. | Max. | Min. | Max. | Min. | Max. | Min. | Max. | |
| TTL Output Module Timing¹ | | | | | | | | | | | | |
| t _{DLH} | Data-to-Pad HIGH | 4.65 | | 5.36 | | 6.08 | | 7.15 | | 10.02 | | ns |
| t _{DHL} | Data-to-Pad LOW | 5.58 | | 6.44 | | 7.29 | | 8.58 | | 12.01 | | ns |
| t _{ENZH} | Enable Pad Z to HIGH | 5.23 | | 6.04 | | 6.84 | | 8.05 | | 11.27 | | ns |
| t _{ENZL} | Enable Pad Z to LOW | 6.56 | | 7.57 | | 8.58 | | 10.09 | | 14.13 | | ns |
| t _{ENHZ} | Enable Pad HIGH to Z | 11.08 | | 12.79 | | 14.49 | | 17.05 | | 23.87 | | ns |
| t _{ENLZ} | Enable Pad LOW to Z | 8.21 | | 9.47 | | 10.73 | | 12.63 | | 17.68 | | ns |
| d _{TLH} | Delta LOW to HIGH | 0.03 | | 0.03 | | 0.04 | | 0.04 | | 0.06 | | ns/pF |
| d _{THL} | Delta HIGH to LOW | 0.04 | | 0.04 | | 0.05 | | 0.06 | | 0.08 | | ns/pF |
| CMOS Output Module Timing¹ | | | | | | | | | | | | |
| t _{DLH} | Data-to-Pad HIGH | 5.51 | | 6.35 | | 7.20 | | 8.47 | | 11.86 | | ns |
| t _{DHL} | Data-to-Pad LOW | 4.75 | | 5.48 | | 6.21 | | 7.31 | | 10.23 | | ns |
| t _{ENZH} | Enable Pad Z to HIGH | 4.72 | | 5.45 | | 6.18 | | 7.27 | | 10.17 | | ns |
| t _{ENZL} | Enable Pad Z to LOW | 6.83 | | 7.89 | | 8.94 | | 10.51 | | 14.72 | | ns |
| t _{ENHZ} | Enable Pad HIGH to Z | 11.08 | | 12.79 | | 14.49 | | 17.05 | | 23.87 | | ns |
| t _{ENLZ} | Enable Pad LOW to Z | 8.21 | | 9.47 | | 10.73 | | 12.63 | | 17.68 | | ns |
| d _{TLH} | Delta LOW to HIGH | 0.05 | | 0.05 | | 0.06 | | 0.07 | | 0.10 | | ns/pF |
| d _{THL} | Delta HIGH to LOW | 0.03 | | 0.03 | | 0.04 | | 0.04 | | 0.06 | | ns/pF |

Notes:

- Delays based on 35 pF loading.

A40MX04 Timing Characteristics (Nominal 5.0V Operation)
 (Worst-Case Commercial Conditions, V_{CC} = 4.75V, T_J = 70°C)

| Logic Module Propagation Delays | | '-3' Speed | | '-2' Speed | | '-1' Speed | | 'Std' Speed | | '-F' Speed | | |
|---|--|------------|--------|------------|--------|------------|--------|-------------|--------|------------|-------|-------|
| Parameter | Description | Min. | Max. | Min. | Max. | Min. | Max. | Min. | Max. | Min. | Max. | Units |
| t _{PD1} | Single Module | | 1.24 | | 1.43 | | 1.62 | | 1.90 | | 2.66 | ns |
| t _{PD2} | Dual-Module Macros | | 2.25 | | 3.06 | | 3.47 | | 4.08 | | 5.71 | ns |
| t _{CO} | Sequential Clock-to-Q | | 1.24 | | 1.43 | | 1.62 | | 1.90 | | 2.66 | ns |
| t _{GO} | Latch G-to-Q | | 1.24 | | 1.43 | | 1.62 | | 1.90 | | 2.66 | ns |
| t _{RS} | Flip-Flop (Latch) Reset-to-Q | | 1.24 | | 1.43 | | 1.62 | | 1.90 | | 2.66 | ns |
| Predicted Routing Delays¹ | | | | | | | | | | | | |
| t _{RD1} | FO=1 Routing Delay | | 1.17 | | 1.59 | | 1.80 | | 2.12 | | 2.97 | ns |
| t _{RD2} | FO=2 Routing Delay | | 1.90 | | 2.19 | | 2.48 | | 2.92 | | 4.09 | ns |
| t _{RD3} | FO=3 Routing Delay | | 2.42 | | 2.80 | | 3.17 | | 3.73 | | 5.22 | ns |
| t _{RD4} | FO=4 Routing Delay | | 2.94 | | 3.40 | | 3.85 | | 4.53 | | 6.34 | ns |
| t _{RD8} | FO=8 Routing Delay | | 5.04 | | 5.81 | | 6.59 | | 7.75 | | 10.85 | ns |
| Sequential Timing Characteristics | | | | | | | | | | | | |
| t _{SUD} ² | Flip-Flop (Latch) Data Input Set-Up | 3.06 | | 3.53 | | 4.00 | | 4.70 | | 6.58 | | ns |
| t _{HD} ³ | Flip-Flop (Latch) Data Input Hold | 0.00 | | 0.00 | | 0.00 | | 0.00 | | 0.00 | | ns |
| t _{SUENA} | Flip-Flop (Latch) Enable Set-Up | 3.06 | | 3.53 | | 4.00 | | 4.70 | | 6.58 | | ns |
| t _{HENA} | Flip-Flop (Latch) Enable Hold | 0.00 | | 0.00 | | 0.00 | | 0.00 | | 0.00 | | ns |
| t _{WCLKA} | Flip-Flop (Latch) Clock Active Pulse Width | 3.25 | | 3.75 | | 4.25 | | 5.00 | | 7.00 | | ns |
| t _{WASYN} | Flip-Flop (Latch) Asynchronous Pulse Width | 3.25 | | 3.75 | | 4.25 | | 5.00 | | 7.00 | | ns |
| t _A | Flip-Flop Clock Input Period | 4.84 | | 5.59 | | 6.33 | | 7.45 | | 10.43 | | ns |
| f _{MAX} | Flip-Flop (Latch) Clock Frequency (FO = 128) | | 180.90 | | 167.00 | | 154.10 | | 134.00 | | 80.40 | MHz |

Notes:

1. Routing delays are for typical designs across worst-case operating conditions. These parameters should be used for estimating device performance. Post-route timing analysis or simulation is required to determine actual worst-case performance. Post-route timing is based on actual routing delay measurements performed on the device prior to shipment.
2. Set-up times assume fanout of 3. Further testing information can be obtained from the Direct Time Analyzer utility.
3. The hold time for the DFME1A macro may be greater than 0ns. Use the Designer 3.0 or later Direct Time Analyzer to check the hold time for this macro.



A40MX04 Timing Characteristics (Nominal 5.0V Operation)

(continued)

(Worst-Case Commercial Conditions)

| Input Module Propagation Delays | | | '-3' Speed | | '-2' Speed | | '-1' Speed | | 'Std' Speed | | '-F' Speed | | |
|--|--------------------------|----------|------------|--------|------------|--------|------------|--------|-------------|--------|------------|-------|-------|
| Parameter | Description | | Min. | Max. | Min. | Max. | Min. | Max. | Min. | Max. | Min. | Max. | Units |
| t _{INYH} | Pad-to-Y HIGH | | | 0.70 | | 0.80 | | 0.91 | | 1.07 | | 1.50 | ns |
| t _{INYL} | Pad-to-Y LOW | | | 0.62 | | 0.71 | | 0.81 | | 0.95 | | 1.33 | ns |
| Input Module Predicted Routing Delays ¹ | | | | | | | | | | | | | |
| t _{IRD1} | FO=1 Routing Delay | | | 2.07 | | 2.39 | | 2.17 | | 3.19 | | 4.47 | ns |
| t _{IRD2} | FO=2 Routing Delay | | | 2.59 | | 2.99 | | 3.39 | | 3.99 | | 5.59 | ns |
| t _{IRD3} | FO=3 Routing Delay | | | 3.12 | | 3.60 | | 4.08 | | 4.80 | | 6.72 | ns |
| t _{IRD4} | FO=4 Routing Delay | | | 3.64 | | 4.20 | | 4.76 | | 5.60 | | 7.84 | ns |
| t _{IRD8} | FO=8 Routing Delay | | | 5.73 | | 6.62 | | 7.50 | | 8.82 | | 12.35 | ns |
| Global Clock Network | | | | | | | | | | | | | |
| t _{CKH} | Input LOW to HIGH | FO = 16 | | 4.58 | | 5.29 | | 5.99 | | 7.05 | | 9.87 | ns |
| | | FO = 128 | | 4.58 | | 5.29 | | 5.99 | | 7.05 | | 9.87 | |
| t _{CKL} | Input HIGH to LOW | FO = 16 | | 4.84 | | 5.59 | | 6.33 | | 7.45 | | 10.43 | ns |
| | | FO = 128 | | 4.84 | | 5.59 | | 6.33 | | 7.45 | | 10.43 | |
| t _{PWH} | Minimum Pulse Width HIGH | FO = 16 | 2.24 | | 2.58 | | 2.92 | | 3.44 | | 4.82 | | ns |
| | | FO = 128 | 2.35 | | 2.71 | | 3.07 | | 3.61 | | 5.05 | | |
| t _{PWL} | Minimum Pulse Width LOW | FO = 16 | 2.24 | | 2.58 | | 2.92 | | 3.44 | | 4.82 | | ns |
| | | FO = 128 | 2.35 | | 2.71 | | 3.07 | | 3.61 | | 5.05 | | |
| t _{CKSW} | Maximum Skew | FO = 16 | | 0.39 | | 0.45 | | 0.51 | | 0.60 | | 0.84 | ns |
| | | FO = 128 | | 0.53 | | 0.62 | | 0.70 | | 0.82 | | 1.15 | |
| t _p | Minimum Period | FO = 16 | 4.69 | | 5.39 | | 6.10 | | 7.18 | | 10.05 | | ns |
| | | FO = 128 | 4.84 | | 5.59 | | 6.33 | | 7.45 | | 10.43 | | |
| f _{MAX} | Maximum Frequency | FO = 16 | | 187.68 | | 174.79 | | 159.85 | | 139.00 | | 83.40 | MHz |
| | | FO = 128 | | 180.90 | | 167.50 | | 154.10 | | 134.00 | | 80.40 | |

Note:

- These parameters should be used for estimating device performance. Optimization techniques may further reduce delays by 0 to 4 ns. Routing delays are for typical designs across worst-case operating conditions. Post-route timing analysis or simulation is required to determine actual worst-case performance. Post-route timing is based on actual routing delay measurements performed on the device prior to shipment.

A40MX04 Timing Characteristics (Nominal 5.0V Operation)

(continued)

(Worst-Case Commercial Conditions)

| Output Module Timing | | '-3' Speed | | '-2' Speed | | '-1' Speed | | 'Std' Speed | | '-F' Speed | | |
|--|----------------------|------------|------|------------|------|------------|-------|-------------|-------|------------|-------|-------|
| Parameter | Description | Min. | Max. | Min. | Max. | Min. | Max. | Min. | Max. | Min. | Max. | Units |
| TTL Output Module Timing¹ | | | | | | | | | | | | |
| t _{DLH} | Data-to-Pad HIGH | | 3.32 | | 3.83 | | 4.34 | | 5.11 | | 7.15 | ns |
| t _{DHL} | Data-to-Pad LOW | | 3.98 | | 4.60 | | 5.21 | | 6.13 | | 8.58 | ns |
| t _{ENZH} | Enable Pad Z to HIGH | | 3.74 | | 4.31 | | 4.89 | | 5.75 | | 8.05 | ns |
| t _{ENZL} | Enable Pad Z to LOW | | 4.69 | | 5.41 | | 6.13 | | 7.21 | | 10.09 | ns |
| t _{ENHZ} | Enable Pad HIGH to Z | | 7.92 | | 9.14 | | 10.35 | | 12.18 | | 17.05 | ns |
| t _{ENLZ} | Enable Pad LOW to Z | | 5.86 | | 6.77 | | 7.67 | | 9.02 | | 12.63 | ns |
| d _{TLH} | Delta LOW to HIGH | | 0.02 | | 0.02 | | 0.03 | | 0.03 | | 0.04 | ns/pF |
| d _{THL} | Delta HIGH to LOW | | 0.02 | | 0.03 | | 0.03 | | 0.04 | | 0.06 | ns/pF |
| CMOS Output Module Timing¹ | | | | | | | | | | | | |
| t _{DLH} | Data-to-Pad HIGH | | 3.93 | | 4.54 | | 5.14 | | 6.05 | | 8.47 | ns |
| t _{DHL} | Data-to-Pad LOW | | 3.39 | | 3.92 | | 4.44 | | 5.22 | | 7.31 | ns |
| t _{ENZH} | Enable Pad Z to HIGH | | 3.37 | | 3.89 | | 4.41 | | 5.19 | | 7.27 | ns |
| t _{ENZL} | Enable Pad Z to LOW | | 4.88 | | 5.63 | | 6.38 | | 7.51 | | 10.51 | ns |
| t _{ENHZ} | Enable Pad HIGH to Z | | 7.92 | | 9.14 | | 10.35 | | 12.18 | | 17.05 | ns |
| t _{ENLZ} | Enable Pad LOW to Z | | 4.98 | | 6.77 | | 7.67 | | 9.02 | | 12.63 | ns |
| d _{TLH} | Delta LOW to HIGH | | 0.03 | | 0.04 | | 0.04 | | 0.05 | | 0.07 | ns/pF |
| d _{THL} | Delta HIGH to LOW | | 0.02 | | 0.02 | | 0.03 | | 0.03 | | 0.04 | ns/pF |

Notes:

- Delays based on 35 pF loading.



A40MX04 Timing Characteristics (Nominal 3.3V Operation)
 (Worst-Case Commercial Conditions, V_{CC} = 3.0V, T_J = 70°C)

| Logic Module Propagation Delays | | '-3' Speed | | '-2' Speed | | '-1' Speed | | 'Std' Speed | | '-F' Speed | | Units |
|--|--|------------|--------|------------|--------|------------|-------|-------------|-------|------------|-------|-------|
| | | Min. | Max. | Min. | Max. | Min. | Max. | Min. | Max. | Min. | Max. | |
| t _{PD1} | Single Module | | 1.73 | | 2.00 | | 2.26 | | 2.66 | | 3.72 | ns |
| t _{PD2} | Dual-Module Macros | | 3.71 | | 4.28 | | 4.86 | | 5.71 | | 8.00 | ns |
| t _{CO} | Sequential Clock-to-Q | | 1.73 | | 2.00 | | 2.26 | | 2.66 | | 3.72 | ns |
| t _{GO} | Latch G-to-Q | | 1.73 | | 2.00 | | 2.26 | | 2.66 | | 3.72 | ns |
| t _{RS} | Flip-Flop (Latch) Reset-to-Q | | 1.73 | | 2.00 | | 2.26 | | 2.66 | | 3.72 | ns |
| Predicted Routing Delays¹ | | | | | | | | | | | | |
| t _{RD1} | FO=1 Routing Delay | | 1.93 | | 2.23 | | 2.52 | | 2.97 | | 4.16 | ns |
| t _{RD2} | FO=2 Routing Delay | | 2.66 | | 3.07 | | 3.47 | | 4.09 | | 5.72 | ns |
| t _{RD3} | FO=3 Routing Delay | | 3.39 | | 3.92 | | 4.44 | | 5.22 | | 7.31 | ns |
| t _{RD4} | FO=4 Routing Delay | | 4.12 | | 4.76 | | 5.39 | | 6.34 | | 8.88 | ns |
| t _{RD8} | FO=8 Routing Delay | | 7.05 | | 8.14 | | 9.22 | | 10.85 | | 15.19 | ns |
| Sequential Timing Characteristics² | | | | | | | | | | | | |
| t _{SUD} | Flip-Flop (Latch) Data Input Set-Up | 4.28 | | 4.94 | | 5.59 | | 6.58 | | 9.21 | | ns |
| t _{HD} ³ | Flip-Flop (Latch) Data Input Hold | 0.00 | | 0.00 | | 0.00 | | 0.00 | | 0.00 | | ns |
| t _{SUENA} | Flip-Flop (Latch) Enable Set-Up | 4.28 | | 4.94 | | 5.59 | | 6.58 | | 9.21 | | ns |
| t _{HENA} | Flip-Flop (Latch) Enable Hold | 0.00 | | 0.00 | | 0.00 | | 0.00 | | 0.00 | | ns |
| t _{WCLKA} | Flip-Flop (Latch) Clock Active Pulse Width | 4.55 | | 5.25 | | 5.95 | | 7.00 | | 9.80 | | ns |
| t _{WASYN} | Flip-Flop (Latch) Asynchronous Pulse Width | 4.55 | | 5.25 | | 5.95 | | 7.00 | | 9.80 | | ns |
| t _A | Flip-Flop Clock Input Period | 6.78 | | 7.82 | | 8.87 | | 10.43 | | 14.60 | | ns |
| f _{MAX} | Flip-Flop (Latch) Clock Frequency (FO = 128) | | 108.54 | | 100.50 | | 92.46 | | 80.40 | | 48.24 | MHz |

Notes:

- Routing delays are for typical designs across worst-case operating conditions. These parameters should be used for estimating device performance. Post-route timing analysis or simulation is required to determine actual worst-case performance. Post-route timing is based on actual routing delay measurements performed on the device prior to shipment.
- Set-up times assume fanout of 3. Further testing information can be obtained from the DirectTime Analyzer utility.
- The hold time for the DFMEIA macro may be greater than 0ns. Use the Designer 3.0 or later DirectTime Analyzer to check the hold time for this macro.

A40MX04 Timing Characteristics (Nominal 3.3V Operation)

(continued)

(Worst-Case Commercial Conditions).

| Input Module Propagation Delays | | | '-3' Speed | | '-2' Speed | | '-1' Speed | | 'Std' Speed | | '-F' Speed | | |
|--|-----------------------------|----------|------------|--------|------------|--------|------------|-------|-------------|-------|------------|-------|-------|
| Parameter Description | | | Min. | Max. | Min. | Max. | Min. | Max. | Min. | Max. | Min. | Max. | Units |
| t _{INYH} | Pad-to-Y HIGH | | | 0.97 | | 1.12 | | 1.27 | | 1.50 | | 2.10 | ns |
| t _{INYL} | Pad-to-Y LOW | | | 0.86 | | 1.00 | | 1.13 | | 1.33 | | 1.86 | ns |
| Input Module Predicted Routing Delays ¹ | | | | | | | | | | | | | |
| t _{IRD1} | FO=1 Routing Delay | | | 2.90 | | 3.35 | | 3.80 | | 4.47 | | 6.25 | ns |
| t _{IRD2} | FO=2 Routing Delay | | | 3.63 | | 4.19 | | 4.75 | | 5.59 | | 7.82 | ns |
| t _{IRD3} | FO=3 Routing Delay | | | 4.37 | | 5.04 | | 5.71 | | 6.72 | | 9.41 | ns |
| t _{IRD4} | FO=4 Routing Delay | | | 5.10 | | 5.88 | | 6.66 | | 7.84 | | 10.98 | ns |
| t _{IRD8} | FO=8 Routing Delay | | | 8.03 | | 9.26 | | 10.50 | | 12.35 | | 17.29 | ns |
| Global Clock Network | | | | | | | | | | | | | |
| t _{CKH} | Input LOW to HIGH | FO = 16 | | 6.42 | | 7.40 | | 8.39 | | 9.87 | | 13.82 | ns |
| | | FO = 128 | | 6.42 | | 7.40 | | 8.39 | | 9.87 | | 13.82 | |
| t _{CKL} | Input HIGH to LOW | FO = 16 | | 6.78 | | 7.82 | | 8.87 | | 10.43 | | 14.60 | ns |
| | | FO = 128 | | 6.78 | | 7.82 | | 8.87 | | 10.43 | | 14.60 | |
| t _{PWH} | Minimum Pulse Width HIGH | FO = 16 | 3.13 | | 3.61 | | 4.09 | | 4.82 | | 6.74 | ns | |
| | | FO = 128 | 3.29 | | 3.79 | | 4.30 | | 5.05 | | 7.08 | | |
| t _{PWL} | Minimum Pulse Width LOW | FO = 16 | 3.13 | | 3.61 | | 4.09 | | 4.82 | | 6.74 | ns | |
| | | FO = 128 | 3.29 | | 3.79 | | 4.30 | | 5.05 | | 7.08 | | |
| t _{CKSW} | Maximum Skew | FO = 16 | | 0.55 | | 0.63 | | 0.71 | | 0.84 | | 1.18 | ns |
| | | FO = 128 | | 0.75 | | 0.86 | | 0.98 | | 1.15 | | 1.61 | |
| t _P | Minimum Period | FO = 16 | 6.53 | | 7.54 | | 8.54 | | 10.05 | | 14.07 | ns | |
| | | FO = 128 | 6.78 | | 7.82 | | 8.87 | | 10.43 | | 14.60 | | |
| f _{MAX} | Maximum Frequency | FO = 16 | | 112.50 | | 104.88 | | 95.91 | | 83.40 | | 50.04 | MHz |
| | | FO = 128 | | 108.54 | | 100.50 | | 92.46 | | 80.40 | | 48.24 | |

Note:

- These parameters should be used for estimating device performance. Optimization techniques may further reduce delays by 0 to 4 ns. Routing delays are for typical designs across worst-case operating conditions. Post-route timing analysis or simulation is required to determine actual worst-case performance. Post-route timing is based on actual routing delay measurements performed on the device prior to shipment.



A40MX04 Timing Characteristics (Nominal 3.3V Operation)

(continued)

(Worst-Case Commercial Conditions)

| Output Module Timing | | '-3' Speed | | '-2' Speed | | '-1' Speed | | 'Std' Speed | | '-F' Speed | | |
|--|----------------------|------------|-------|------------|-------|------------|-------|-------------|-------|------------|-------|-------|
| Parameter | Description | Min. | Max. | Min. | Max. | Min. | Max. | Min. | Max. | Min. | Max. | Units |
| TTL Output Module Timing¹ | | | | | | | | | | | | |
| t _{DLH} | Data-to-Pad HIGH | | 4.65 | | 5.37 | | 6.08 | | 7.15 | | 10.02 | ns |
| t _{DHL} | Data-to-Pad LOW | | 5.58 | | 6.44 | | 7.29 | | 8.58 | | 12.01 | ns |
| t _{ENZH} | Enable Pad Z to HIGH | | 5.23 | | 6.04 | | 6.84 | | 8.05 | | 11.27 | ns |
| t _{ENZL} | Enable Pad Z to LOW | | 6.56 | | 7.57 | | 8.58 | | 10.09 | | 14.13 | ns |
| t _{ENHZ} | Enable Pad HIGH to Z | | 11.08 | | 12.79 | | 14.49 | | 17.05 | | 23.87 | ns |
| t _{ENLZ} | Enable Pad LOW to Z | | 8.21 | | 9.47 | | 10.73 | | 12.63 | | 17.68 | ns |
| d _{TLH} | Delta LOW to HIGH | | 0.03 | | 0.03 | | 0.04 | | 0.04 | | 0.06 | ns/pF |
| d _{THL} | Delta HIGH to LOW | | 0.04 | | 0.04 | | 0.05 | | 0.06 | | 0.08 | ns/pF |
| CMOS Output Module Timing¹ | | | | | | | | | | | | |
| t _{DLH} | Data-to-Pad HIGH | | 5.51 | | 6.35 | | 7.20 | | 8.47 | | 11.86 | ns |
| t _{DHL} | Data-to-Pad LOW | | 4.75 | | 5.48 | | 6.21 | | 7.31 | | 10.23 | ns |
| t _{ENZH} | Enable Pad Z to HIGH | | 4.72 | | 5.45 | | 6.18 | | 7.27 | | 10.17 | ns |
| t _{ENZL} | Enable Pad Z to LOW | | 6.83 | | 7.89 | | 8.94 | | 10.51 | | 14.72 | ns |
| t _{ENHZ} | Enable Pad HIGH to Z | | 11.08 | | 12.79 | | 14.49 | | 17.05 | | 23.87 | ns |
| t _{ENLZ} | Enable Pad LOW to Z | | 8.21 | | 9.47 | | 10.73 | | 12.63 | | 17.68 | ns |
| d _{TLH} | Delta LOW to HIGH | | 0.05 | | 0.05 | | 0.06 | | 0.07 | | 0.10 | ns/pF |
| d _{THL} | Delta HIGH to LOW | | 0.03 | | 0.03 | | 0.04 | | 0.04 | | 0.06 | ns/pF |

Notes:

- Delays based on 35 pF loading.

A42MX09 Timing Characteristics (Nominal 5.0V Operation)

(Worst-Case Commercial Conditions, $V_{CC} = 4.75V$, $T_J = 70^\circ C$)

| Logic Module Propagation Delays ¹ | | '-2' Speed | | '-1' Speed | | 'Std' Speed | | '-F' Speed | | |
|--|--|------------|--------|------------|--------|-------------|--------|------------|--------|-------|
| Parameter | Description | Min. | Max. | Min. | Max. | Min. | Max. | Min. | Max. | Units |
| t_{PD1} | Single Module | | 1.33 | | 1.50 | | 1.77 | | 2.48 | ns |
| t_{CO} | Sequential Clock-to-Q | | 1.43 | | 1.62 | | 1.91 | | 2.67 | ns |
| t_{GO} | Latch G-to-Q | | 1.37 | | 1.55 | | 1.82 | | 2.55 | ns |
| t_{RS} | Flip-Flop (Latch) Reset-to-Q | | 1.58 | | 1.79 | | 2.10 | | 2.94 | ns |
| Predicted Routing Delays ² | | | | | | | | | | |
| t_{RD1} | FO=1 Routing Delay | | 0.77 | | 0.87 | | 1.02 | | 1.43 | ns |
| t_{RD2} | FO=2 Routing Delay | | 1.02 | | 1.16 | | 1.36 | | 1.90 | ns |
| t_{RD3} | FO=3 Routing Delay | | 1.28 | | 1.45 | | 1.70 | | 2.38 | ns |
| t_{RD4} | FO=4 Routing Delay | | 1.53 | | 1.73 | | 2.04 | | 2.86 | ns |
| t_{RD8} | FO=8 Routing Delay | | 2.60 | | 2.90 | | 3.41 | | 4.77 | ns |
| Sequential Timing Characteristics ^{3,4} | | | | | | | | | | |
| t_{SUD} | Flip-Flop (Latch) Data Input Set-Up | 0.36 | | 0.41 | | 0.48 | | 0.67 | | ns |
| t_{HD} | Flip-Flop (Latch) Data Input Hold | 0.00 | | 0.00 | | 0.00 | | 0.00 | | ns |
| t_{SUENA} | Flip-Flop (Latch) Enable Set-Up | 0.45 | | 0.51 | | 0.60 | | 0.84 | | ns |
| t_{HENA} | Flip-Flop (Latch) Enable Hold | 0.00 | | 0.00 | | 0.00 | | 0.00 | | ns |
| t_{WCLKA} | Flip-Flop (Latch) Clock Active Pulse Width | 3.77 | | 4.27 | | 5.02 | | 7.03 | | ns |
| t_{WASYN} | Flip-Flop (Latch) Asynchronous Pulse Width | 4.94 | | 5.59 | | 6.58 | | 9.21 | | ns |
| t_A | Flip-Flop Clock Input Period | 3.83 | | 4.34 | | 5.10 | | 7.14 | | ns |
| t_{INH} | Input Buffer Latch Hold | 0.00 | | 0.00 | | 0.00 | | 0.00 | | ns |
| t_{INSU} | Input Buffer Latch Set-Up | 0.30 | | 0.40 | | 0.40 | | 0.60 | | ns |
| t_{OUTH} | Output Buffer Latch Hold | 0.00 | | 0.00 | | 0.00 | | 0.00 | | ns |
| t_{OUTSU} | Output Buffer Latch Set-Up | 0.30 | | 0.40 | | 0.40 | | 0.60 | | ns |
| f_{MAX} | Flip-Flop (Latch) Clock Frequency | | 243.75 | | 224.25 | | 195.00 | | 117.00 | MHz |

Notes:

- For dual-module macros, use $t_{PD1} + t_{RD1} + t_{PDn}$, $t_{CO} + t_{RD1} + t_{PDn}$, or $t_{PD1} + t_{RD1} + t_{SUD}$, whichever is appropriate.
- Routing delays are for typical designs across worst-case operating conditions. These parameters should be used for estimating device performance. Post-route timing analysis or simulation is required to determine actual worst-case performance. Post-route timing is based on actual routing delay measurements performed on the device prior to shipment.
- Data applies to macros based on the S-module. Timing parameters for sequential macros constructed from C-modules can be obtained from the Direct Time Analyzer utility.
- Set-up and hold timing parameters for the input buffer latch are defined with respect to the PAD and the Dinut. External setup/hold timing parameters must account for delay from an external PAD signal to the G inputs. Delay from an external PAD signal to the G input subtracts (adds) to the internal setup (hold) time.



A42MX09 Timing Characteristics (Nominal 5.0V Operation)

(continued)

(Worst-Case Commercial Conditions)

| Input Module Propagation Delays | | | '-2' Speed | | '-1' Speed | | 'Std' Speed | | '-F' Speed | | |
|--|-----------------------------|----------|------------|--------|------------|--------|-------------|--------|------------|--------|-------|
| Parameter | Description | | Min. | Max. | Min. | Max. | Min. | Max. | Min. | Max. | Units |
| t _{INYH} | Pad-to-Y HIGH | | | 1.16 | | 1.32 | | 1.55 | | 2.17 | ns |
| t _{INYL} | Pad-to-Y LOW | | | 0.90 | | 1.02 | | 1.20 | | 1.68 | ns |
| t _{INGH} | G to Y HIGH | | | 1.43 | | 1.62 | | 1.90 | | 2.66 | ns |
| t _{INGL} | G to Y LOW | | | 1.43 | | 1.62 | | 1.90 | | 2.66 | ns |
| Input Module Predicted Routing Delays ¹ | | | | | | | | | | | |
| t _{IRD1} | FO=1 Routing Delay | | | 2.24 | | 2.54 | | 2.99 | | 4.19 | ns |
| t _{IRD2} | FO=2 Routing Delay | | | 2.51 | | 2.85 | | 3.35 | | 4.69 | ns |
| t _{IRD3} | FO=3 Routing Delay | | | 2.78 | | 3.15 | | 3.71 | | 5.19 | ns |
| t _{IRD4} | FO=4 Routing Delay | | | 3.05 | | 3.46 | | 4.07 | | 5.70 | ns |
| t _{IRD8} | FO=8 Routing Delay | | | 4.13 | | 4.68 | | 5.50 | | 7.70 | ns |
| Global Clock Network | | | | | | | | | | | |
| t _{CKH} | Input LOW to HIGH | FO = 32 | | 4.10 | | 4.65 | | 5.47 | | 7.66 | ns |
| | | FO = 256 | | 4.51 | | 5.11 | | 6.01 | | 8.41 | ns |
| t _{CKL} | Input HIGH to LOW | FO = 32 | | 3.92 | | 4.44 | | 5.22 | | 7.31 | ns |
| | | FO = 256 | | 4.30 | | 4.87 | | 5.73 | | 8.02 | ns |
| t _{PWH} | Minimum Pulse Width HIGH | FO = 32 | 1.35 | | 1.53 | | 1.80 | | 2.52 | | ns |
| | | FO = 256 | 1.46 | | 1.66 | | 1.95 | | 2.73 | | ns |
| t _{PWL} | Minimum Pulse Width LOW | FO = 32 | 1.35 | | 1.53 | | 1.80 | | 2.52 | | ns |
| | | FO = 256 | 1.46 | | 1.66 | | 1.95 | | 2.73 | | ns |
| t _{CKSW} | Maximum Skew | FO = 32 | | 0.34 | | 0.38 | | 0.45 | | 0.63 | ns |
| | | FO = 256 | | 0.34 | | 0.38 | | 0.45 | | 0.63 | ns |
| t _{SUEXT} | Input Latch External Set-Up | FO = 32 | 0.00 | | 0.00 | | 0.00 | | 0.00 | | ns |
| | | FO = 256 | 0.00 | | 0.00 | | 0.00 | | 0.00 | | ns |
| t _{HEXT} | Input Latch External Hold | FO = 32 | 2.60 | | 3.00 | | 3.50 | | 4.90 | | ns |
| | | FO = 256 | 2.43 | | 3.30 | | 3.90 | | 5.46 | | ns |
| t _p | Minimum Period | FO = 32 | 3.72 | | 4.04 | | 4.65 | | 7.75 | | ns |
| | | FO = 256 | 4.10 | | 4.46 | | 5.13 | | 8.55 | | ns |
| f _{MAX} | Maximum Frequency | FO = 32 | | 268.75 | | 247.25 | | 215.00 | | 129.00 | MHz |
| | | FO = 256 | | 243.75 | | 224.25 | | 195.00 | | 117.00 | MHz |

Note:

- These parameters should be used for estimating device performance. Optimization techniques may further reduce delays by 0 to 3 ns. Routing delays are for typical designs across worst-case operating conditions. Post-route timing analysis or simulation is required to determine actual worst case performance

A42MX09 Timing Characteristics (Nominal 5.0V Operation)
(Worst-Case Commercial Conditions)

(continued)

| Output Module Timing | | '-2' Speed | | '-1' Speed | | 'Std' Speed | | '-F' Speed | | |
|--|--|------------|------|------------|------|-------------|-------|------------|-------|-------|
| Parameter | Description | Min. | Max. | Min. | Max. | Min. | Max. | Min. | Max. | Units |
| TTL Output Module Timing¹ | | | | | | | | | | |
| t _{DLH} | Data-to-Pad HIGH | | 2.71 | | 3.07 | | 3.61 | | 5.05 | ns |
| t _{DHL} | Data-to-Pad LOW | | 3.19 | | 3.61 | | 4.25 | | 5.95 | ns |
| t _{ENZH} | Enable Pad Z to HIGH | | 2.93 | | 3.32 | | 3.90 | | 5.46 | ns |
| t _{ENZL} | Enable Pad Z to LOW | | 3.24 | | 3.67 | | 4.32 | | 6.05 | ns |
| t _{ENHZ} | Enable Pad HIGH to Z | | 5.44 | | 6.16 | | 7.25 | | 10.15 | ns |
| t _{ENLZ} | Enable Pad LOW to Z | | 5.93 | | 6.72 | | 7.90 | | 11.06 | ns |
| t _{GLH} | G-to-Pad HIGH | | 4.61 | | 5.22 | | 6.14 | | 8.60 | ns |
| t _{GHL} | G-to-Pad LOW | | 4.61 | | 5.22 | | 6.14 | | 8.60 | ns |
| t _{LSU} | I/O Latch Set-Up | 0.54 | | 0.61 | | 0.72 | | 1.01 | | ns |
| t _{LH} | I/O Latch Hold | 0.00 | | 0.00 | | 0.00 | | 0.00 | | ns |
| t _{LCO} | I/O Latch Clock-to-Out (Pad-to-Pad), 64 Clock Loading | | 5.78 | | 6.55 | | 7.70 | | 10.78 | ns |
| t _{ACO} | Array Clock-to-Out (Pad-to-Pad), 64 Clock Loading | | 8.18 | | 9.27 | | 10.90 | | 15.26 | ns |
| d _{TLH} | Capacity Loading, LOW to HIGH | | 0.03 | | 0.03 | | 0.04 | | 0.06 | ns/pF |
| d _{THL} | Capacity Loading, HIGH to LOW | | 0.04 | | 0.04 | | 0.05 | | 0.07 | ns/pF |
| CMOS Output Module Timing¹ | | | | | | | | | | |
| t _{DLH} | Data-to-Pad HIGH | | 2.71 | | 3.07 | | 3.61 | | 5.05 | ns |
| t _{DHL} | Data-to-Pad LOW | | 3.19 | | 3.61 | | 4.25 | | 5.95 | ns |
| t _{ENZH} | Enable Pad Z to HIGH | | 2.93 | | 3.32 | | 3.90 | | 5.46 | ns |
| t _{ENZL} | Enable Pad Z to LOW | | 3.24 | | 3.67 | | 4.32 | | 6.05 | ns |
| t _{ENHZ} | Enable Pad HIGH to Z | | 5.44 | | 6.16 | | 7.25 | | 10.15 | ns |
| t _{ENLZ} | Enable Pad LOW to Z | | 5.93 | | 6.72 | | 7.90 | | 11.06 | ns |
| t _{GLH} | G-to-Pad HIGH | | 4.61 | | 5.22 | | 6.14 | | 8.60 | ns |
| t _{GHL} | G-to-Pad LOW | | 4.61 | | 5.22 | | 6.14 | | 8.60 | ns |
| t _{LSU} | I/O Latch Set-Up | 0.54 | | 0.61 | | 0.72 | | 1.01 | | ns |
| t _{LH} | I/O Latch Hold | 0.00 | | 0.00 | | 0.00 | | 0.00 | | ns |
| t _{LCO} | I/O Latch Clock-to-Out (Pad-to-Pad), 64 Clock Loading | | 5.78 | | 6.55 | | 7.70 | | 10.78 | ns |
| t _{ACO} | Array Clock-to-Out (Pad-to-Pad), 64 Clock Loading | | 8.18 | | 9.27 | | 10.90 | | 15.26 | ns |
| d _{TLH} | Capacity Loading, LOW to HIGH | | 0.03 | | 0.03 | | 0.04 | | 0.06 | ns/pF |
| d _{THL} | Capacity Loading, HIGH to LOW | | 0.04 | | 0.04 | | 0.05 | | 0.07 | ns/pF |

Notes:

- Delays based on 35 pF loading.



A42MX09 Timing Characteristics (Nominal 3.3V Operation)

(Worst-Case Commercial Conditions, V_{CC} = 3.0V, T_J = 70°C)

| Logic Module Propagation Delays ¹ | | '-2' Speed | | '-1' Speed | | 'Std' Speed | | '-F' Speed | | |
|---|--|------------|--------|------------|--------|-------------|--------|------------|-------|-------|
| Parameter | Description | Min. | Max. | Min. | Max. | Min. | Max. | Min. | Max. | Units |
| t _{PD1} | Single Module | | 1.80 | | 2.13 | | 2.50 | | 3.47 | ns |
| t _{CO} | Sequential Clock-to-Q | | 2.00 | | 2.30 | | 2.70 | | 3.76 | ns |
| t _{GO} | Latch G-to-Q | | 1.88 | | 2.13 | | 2.50 | | 3.50 | ns |
| t _{RS} | Flip-Flop (Latch) Reset-to-Q | | 2.18 | | 2.47 | | 2.90 | | 4.06 | ns |
| Predicted Routing Delays ² | | | | | | | | | | |
| t _{RD1} | FO=1 Routing Delay | | 1.10 | | 1.20 | | 1.40 | | 2.00 | ns |
| t _{RD2} | FO=2 Routing Delay | | 1.40 | | 1.60 | | 1.90 | | 2.67 | ns |
| t _{RD3} | FO=3 Routing Delay | | 1.80 | | 2.00 | | 2.40 | | 3.33 | ns |
| t _{RD4} | FO=4 Routing Delay | | 2.10 | | 2.40 | | 2.90 | | 4.00 | ns |
| t _{RD8} | FO=8 Routing Delay | | 3.60 | | 4.10 | | 4.80 | | 6.68 | ns |
| Sequential Timing Characteristics ^{3, 4} | | | | | | | | | | |
| t _{SUD} | Flip-Flop (Latch) Data Input Set-Up | 0.50 | | 0.57 | | 0.67 | | 0.94 | | ns |
| t _{HD} | Flip-Flop (Latch) Data Input Hold | 0.00 | | 0.00 | | 0.00 | | 0.00 | | ns |
| t _{SUENA} | Flip-Flop (Latch) Enable Set-Up | 0.63 | | 0.71 | | 0.84 | | 1.18 | | ns |
| t _{HENA} | Flip-Flop (Latch) Enable Hold | 0.00 | | 0.00 | | 0.00 | | 0.00 | | ns |
| t _{WCLKA} | Flip-Flop (Latch) Clock Active Pulse Width | 5.27 | | 5.97 | | 7.03 | | 9.84 | | ns |
| t _{WASYN} | Flip-Flop (Latch) Asynchronous Pulse Width | 6.91 | | 7.83 | | 9.21 | | 12.90 | | ns |
| t _A | Flip-Flop Clock Input Period | 5.60 | | 6.20 | | 7.10 | | 9.94 | | ns |
| t _{INH} | Input Buffer Latch Hold | 0.00 | | 0.00 | | 0.00 | | 0.00 | | ns |
| t _{INSU} | Input Buffer Latch Set-Up | 0.30 | | 0.34 | | 0.40 | | 0.56 | | ns |
| t _{OUTH} | Output Buffer Latch Hold | 0.00 | | 0.00 | | 0.00 | | 0.00 | | ns |
| t _{OUTSU} | Output Buffer Latch Set-Up | 0.30 | | 0.34 | | 0.40 | | 0.56 | | ns |
| f _{MAX} | Flip-Flop (Latch) Clock Frequency | | 146.30 | | 134.60 | | 117.00 | | 70.20 | MHz |

Notes:

- For dual-module macros, use t_{PD1} + t_{RD1} + t_{PDn}, t_{CO} + t_{RD1} + t_{PDn}, or t_{PD1} + t_{RD1} + t_{SUD}, whichever is appropriate.
- Routing delays are for typical designs across worst-case operating conditions. These parameters should be used for estimating device performance. Post-route timing analysis or simulation is required to determine actual worst-case performance. Post-route timing is based on actual routing delay measurements performed on the device prior to shipment.
- Data applies to macros based on the S-module. Timing parameters for sequential macros constructed from C-modules can be obtained from the DirectTime Analyzer utility.
- Set-up and hold timing parameters for the input buffer latch are defined with respect to the PAD and the D input. External setup/hold timing parameters must account for delay from an external PAD signal to the G inputs. Delay from an external PAD signal to the G input subtracts (adds) to the internal setup (hold) time.

A42MX09 Timing Characteristics (Nominal 3.3V Operation)

(continued)

(Worst-Case Commercial Conditions)

| Input Module Propagation Delays | | | '-2' Speed | | '-1' Speed | | 'Std' Speed | | '-F' Speed | | |
|--|-----------------------------|----------|------------|--------|------------|--------|-------------|--------|------------|-------|-------|
| Parameter | Description | | Min. | Max. | Min. | Max. | Min. | Max. | Min. | Max. | Units |
| t _{INYH} | Pad-to-Y HIGH | | | 1.63 | | 1.84 | | 2.17 | | 3.04 | ns |
| t _{INYL} | Pad-to-Y LOW | | | 1.30 | | 1.40 | | 1.70 | | 2.40 | ns |
| t _{INGH} | G to Y HIGH | | | 2.00 | | 2.30 | | 2.70 | | 3.72 | ns |
| t _{INGL} | G to Y LOW | | | 2.00 | | 2.30 | | 2.70 | | 3.72 | ns |
| Input Module Predicted Routing Delays ¹ | | | | | | | | | | | |
| t _{IRD1} | FO=1 Routing Delay | | | 3.15 | | 3.57 | | 4.20 | | 5.86 | ns |
| t _{IRD2} | FO=2 Routing Delay | | | 3.50 | | 4.00 | | 4.70 | | 6.57 | ns |
| t _{IRD3} | FO=3 Routing Delay | | | 3.90 | | 4.40 | | 5.20 | | 7.27 | ns |
| t _{IRD4} | FO=4 Routing Delay | | | 4.30 | | 4.85 | | 5.70 | | 7.98 | ns |
| t _{IRD8} | FO=8 Routing Delay | | | 5.80 | | 6.55 | | 7.70 | | 10.78 | ns |
| Global Clock Network | | | | | | | | | | | |
| t _{CKH} | Input LOW to HIGH | FO = 32 | | 6.80 | | 6.55 | | 7.70 | | 10.78 | ns |
| | | FO = 256 | | 6.30 | | 7.14 | | 8.40 | | 11.78 | ns |
| t _{CKL} | Input HIGH to LOW | FO = 32 | | 5.50 | | 6.20 | | 7.30 | | 10.23 | ns |
| | | FO = 256 | | 6.00 | | 6.80 | | 8.00 | | 11.23 | ns |
| t _{PWH} | Minimum Pulse Width HIGH | FO = 32 | 1.89 | | 2.14 | | 2.52 | | 3.53 | | ns |
| | | FO = 256 | 2.05 | | 2.32 | | 2.73 | | 3.82 | | ns |
| t _{PWL} | Minimum Pulse Width LOW | FO = 32 | 1.89 | | 2.14 | | 2.52 | | 3.53 | | ns |
| | | FO = 256 | 2.05 | | 2.32 | | 2.73 | | 3.82 | | ns |
| t _{CKSW} | Maximum Skew | FO = 32 | | 0.47 | | 0.54 | | 0.63 | | 0.88 | ns |
| | | FO = 256 | | 0.47 | | 0.54 | | 0.63 | | 0.88 | ns |
| t _{SUEXT} | Input Latch External Set-Up | FO = 32 | 0.00 | | 0.00 | | 0.00 | | 0.00 | | ns |
| | | FO = 256 | 0.00 | | 0.00 | | 0.00 | | 0.00 | | ns |
| t _{HEXT} | Input Latch External Hold | FO = 32 | 3.70 | | 4.20 | | 4.90 | | 6.86 | | ns |
| | | FO = 256 | 4.10 | | 4.60 | | 5.50 | | 7.64 | | ns |
| t _p | Minimum Period | FO = 32 | 6.20 | | 6.74 | | 7.75 | | 12.90 | | ns |
| | | FO = 256 | 6.80 | | 7.43 | | 8.54 | | 14.20 | | ns |
| f _{MAX} | Maximum Frequency | FO = 32 | | 161.30 | | 148.40 | | 129.00 | | 77.40 | MHz |
| | | FO = 256 | | 146.30 | | 134.60 | | 117.00 | | 70.20 | MHz |

Note:

- These parameters should be used for estimating device performance. Optimization techniques may further reduce delays by 0 to 3 ns. Routing delays are for typical designs across worst-case operating conditions. Post-route timing analysis or simulation is required to determine actual worst case performance



A42MX09 Timing Characteristics (Nominal 3.3V Operation)

(continued)

(Worst-Case Commercial Conditions)

| Output Module Timing | | '-2' Speed | | '-1' Speed | | 'Std' Speed | | '-F' Speed | | |
|--|--|------------|-------|------------|-------|-------------|-------|------------|-------|-------|
| Parameter | Description | Min. | Max. | Min. | Max. | Min. | Max. | Min. | Max. | Units |
| TTL Output Module Timing¹ | | | | | | | | | | |
| t _{DLH} | Data-to-Pad HIGH | | 3.79 | | 4.30 | | 5.05 | | 7.08 | ns |
| t _{DHL} | Data-to-Pad LOW | | 4.46 | | 5.06 | | 5.95 | | 8.33 | ns |
| t _{ENZH} | Enable Pad Z to HIGH | | 4.10 | | 4.64 | | 5.46 | | 7.64 | ns |
| t _{ENZL} | Enable Pad Z to LOW | | 4.54 | | 5.14 | | 6.05 | | 8.47 | ns |
| t _{ENHZ} | Enable Pad HIGH to Z | | 7.61 | | 8.63 | | 10.15 | | 14.21 | ns |
| t _{ENLZ} | Enable Pad LOW to Z | | 8.30 | | 9.40 | | 11.06 | | 15.48 | ns |
| t _{GLH} | G-to-Pad HIGH | | 6.45 | | 7.31 | | 8.60 | | 12.03 | ns |
| t _{GHL} | G-to-Pad LOW | | 6.45 | | 7.31 | | 8.60 | | 12.03 | ns |
| t _{LSU} | I/O Latch Set-Up | 0.76 | | 0.86 | | 1.01 | | 1.41 | | ns |
| t _{LH} | I/O Latch Hold | 0.00 | | 0.00 | | 0.00 | | 0.00 | | ns |
| t _{LCO} | I/O Latch Clock-to-Out (Pad-to-Pad), 64 Clock Loading | | 9.70 | | 10.90 | | 12.90 | | 18.03 | ns |
| t _{ACO} | Array Clock-to-Out (Pad-to-Pad), 64 Clock Loading | | 13.50 | | 15.40 | | 18.10 | | 25.30 | ns |
| d _{TLH} | Capacity Loading, LOW to HIGH | | 0.00 | | 0.00 | | 0.10 | | 0.008 | ns/pF |
| d _{THL} | Capacity Loading, HIGH to LOW | | 0.10 | | 0.10 | | 0.10 | | 0.100 | ns/pF |
| CMOS Output Module Timing¹ | | | | | | | | | | |
| t _{DLH} | Data-to-Pad HIGH | | 3.80 | | 5.45 | | 6.41 | | 8.98 | ns |
| t _{DHL} | Data-to-Pad LOW | | 4.50 | | 4.22 | | 4.97 | | 6.96 | ns |
| t _{ENZH} | Enable Pad Z to HIGH | | 4.10 | | 4.64 | | 5.46 | | 7.64 | ns |
| t _{ENZL} | Enable Pad Z to LOW | | 4.54 | | 5.14 | | 6.05 | | 8.47 | ns |
| t _{ENHZ} | Enable Pad HIGH to Z | | 7.61 | | 8.63 | | 10.15 | | 14.21 | ns |
| t _{ENLZ} | Enable Pad LOW to Z | | 8.30 | | 9.40 | | 11.06 | | 15.48 | ns |
| t _{GLH} | G-to-Pad HIGH | | 6.45 | | 7.31 | | 8.60 | | 12.03 | ns |
| t _{GHL} | G-to-Pad LOW | | 6.45 | | 7.31 | | 8.60 | | 12.03 | ns |
| t _{LSU} | I/O Latch Set-Up | 0.76 | | 0.86 | | 1.01 | | 1.41 | | ns |
| t _{LH} | I/O Latch Hold | 0.00 | | 0.00 | | 0.00 | | 0.00 | | ns |
| t _{LCO} | I/O Latch Clock-to-Out (Pad-to-Pad), 64 Clock Loading | | 9.70 | | 10.90 | | 12.90 | | 18.03 | ns |
| t _{ACO} | Array Clock-to-Out (Pad-to-Pad), 64 Clock Loading | | 13.50 | | 15.40 | | 18.10 | | 25.30 | ns |
| d _{TLH} | Capacity Loading, LOW to HIGH | | 0.00 | | 0.00 | | 0.10 | | 0.08 | ns/pF |
| d _{THL} | Capacity Loading, HIGH to LOW | | 0.10 | | 0.10 | | 0.10 | | 0.10 | ns/pF |

Notes:

- Delays based on 35 pF loading.

A42MX16 Timing Characteristics (Nominal 5.0V Operation)

(Worst-Case Commercial Conditions, V_{CC} = 4.75V, T_J = 70°C)

| Logic Module Propagation Delays ¹ | | '-2' Speed | | '-1' Speed | | 'Std' Speed | | '-F' Speed | | |
|--|--|------------|--------|------------|--------|-------------|--------|------------|-------|-------|
| Parameter | Description | Min. | Max. | Min. | Max. | Min. | Max. | Min. | Max. | Units |
| t _{PD1} | Single Module | | 1.52 | | 1.73 | | 2.03 | | 2.84 | ns |
| t _{CO} | Sequential Clock-to-Q | | 1.60 | | 1.81 | | 2.13 | | 2.98 | ns |
| t _{GO} | Latch G-to-Q | | 1.52 | | 1.73 | | 2.03 | | 2.84 | ns |
| t _{RS} | Flip-Flop (Latch) Reset-to-Q | | 1.74 | | 1.97 | | 2.32 | | 3.25 | ns |
| Predicted Routing Delays ² | | | | | | | | | | |
| t _{RD1} | FO=1 Routing Delay | | 0.86 | | 0.98 | | 1.15 | | 1.61 | ns |
| t _{RD2} | FO=2 Routing Delay | | 1.15 | | 1.30 | | 1.53 | | 2.14 | ns |
| t _{RD3} | FO=3 Routing Delay | | 1.43 | | 1.62 | | 1.91 | | 2.67 | ns |
| t _{RD4} | FO=4 Routing Delay | | 1.72 | | 1.95 | | 2.29 | | 3.21 | ns |
| t _{RD8} | FO=8 Routing Delay | | 2.86 | | 3.24 | | 3.81 | | 5.33 | ns |
| Sequential Timing Characteristics ^{3,4} | | | | | | | | | | |
| t _{SUD} | Flip-Flop (Latch) Data Input Set-Up | 0.36 | | 0.41 | | 0.48 | | 0.67 | | ns |
| t _{HD} | Flip-Flop (Latch) Data Input Hold | 0.00 | | 0.00 | | 0.00 | | 0.00 | | ns |
| t _{SUENA} | Flip-Flop (Latch) Enable Set-Up | 0.75 | | 0.85 | | 1.00 | | 1.40 | | ns |
| t _{HENA} | Flip-Flop (Latch) Enable Hold | 0.00 | | 0.00 | | 0.00 | | 0.00 | | ns |
| t _{WCLKA} | Flip-Flop (Latch) Clock Active Pulse Width | 3.78 | | 4.28 | | 5.04 | | 7.06 | | ns |
| t _{WASYN} | Flip-Flop (Latch) Asynchronous Pulse Width | 4.95 | | 5.61 | | 6.60 | | 9.24 | | ns |
| t _A | Flip-Flop Clock Input Period | 7.56 | | 8.57 | | 10.08 | | 14.11 | | ns |
| t _{INH} | Input Buffer Latch Hold | 0.00 | | 0.00 | | 0.00 | | 0.00 | | ns |
| t _{INSU} | Input Buffer Latch Set-Up | 0.54 | | 0.61 | | 0.72 | | 1.01 | | ns |
| t _{OUTH} | Output Buffer Latch Hold | 0.00 | | 0.00 | | 0.00 | | 0.00 | | ns |
| t _{OUTSU} | Output Buffer Latch Set-Up | 0.54 | | 0.61 | | 0.72 | | 1.01 | | ns |
| f _{MAX} | Flip-Flop (Latch) Clock Frequency | | 195.00 | | 179.40 | | 156.00 | | 93.60 | MHz |

Notes:

- For dual-module macros, use t_{PD1} + t_{RD1} + t_{PDn}, t_{CO} + t_{RD1} + t_{PDn}, or t_{PD1} + t_{RD1} + t_{SUD}, point and position whichever is appropriate.
- Routing delays are for typical designs across worst-case operating conditions. These parameters should be used for estimating device performance. Post-route timing analysis or simulation is required to determine actual worst-case performance. Post-route timing is based on actual routing delay measurements performed on the device prior to shipment.
- Data applies to macros based on the S-module. Timing parameters for sequential macros constructed from C-modules can be obtained from the DirectTime Analyzer utility.
- Set-up and hold timing parameters for the input buffer latch are defined with respect to the PAD and the Dinput. External setup/hold timing parameters must account for delay from an external PAD signal to the G inputs. Delay from an external PAD signal to the G input subtracts (adds) to the internal setup (hold) time.



A42MX16 Timing Characteristics (Nominal 5.0V Operation)

(continued)

(Worst-Case Commercial Conditions)

| Input Module Propagation Delays | | | '-2' Speed | | '-1' Speed | | 'Std' Speed | | '-F' Speed | | |
|--|-----------------------------|----------|------------|--------|------------|--------|-------------|--------|------------|--------|-------|
| Parameter | Description | | Min. | Max. | Min. | Max. | Min. | Max. | Min. | Max. | Units |
| t _{INYH} | Pad-to-Y HIGH | | | 1.17 | | 1.33 | | 1.56 | | 2.18 | ns |
| t _{INYL} | Pad-to-Y LOW | | | 0.90 | | 1.02 | | 1.20 | | 1.68 | ns |
| t _{INGH} | G to Y HIGH | | | 1.56 | | 1.77 | | 2.08 | | 2.91 | ns |
| t _{INGL} | G to Y LOW | | | 1.56 | | 1.77 | | 2.08 | | 2.91 | ns |
| Input Module Predicted Routing Delays ¹ | | | | | | | | | | | |
| t _{IRD1} | FO=1 Routing Delay | | | 2.03 | | 2.30 | | 2.71 | | 3.79 | ns |
| t _{IRD2} | FO=2 Routing Delay | | | 2.32 | | 2.63 | | 3.09 | | 4.33 | ns |
| t _{IRD3} | FO=3 Routing Delay | | | 2.60 | | 2.95 | | 3.47 | | 4.86 | ns |
| t _{IRD4} | FO=4 Routing Delay | | | 2.89 | | 3.27 | | 3.85 | | 5.39 | ns |
| t _{IRD8} | FO=8 Routing Delay | | | 4.03 | | 4.56 | | 5.37 | | 7.52 | ns |
| Global Clock Network | | | | | | | | | | | |
| t _{CKH} | Input LOW to HIGH | FO = 32 | | 4.50 | | 5.10 | | 6.00 | | 8.40 | ns |
| | | FO = 384 | | 5.25 | | 5.95 | | 7.00 | | 9.80 | ns |
| t _{CKL} | Input HIGH to LOW | FO = 32 | | 4.20 | | 4.76 | | 5.60 | | 7.84 | ns |
| | | FO = 384 | | 4.95 | | 5.61 | | 6.60 | | 9.24 | ns |
| t _{PWH} | Minimum Pulse Width HIGH | FO = 32 | 3.53 | | 4.00 | | 4.70 | | 6.58 | | ns |
| | | FO = 384 | 4.05 | | 4.59 | | 5.40 | | 7.56 | | ns |
| t _{PWL} | Minimum Pulse Width LOW | FO = 32 | 3.53 | | 4.00 | | 4.70 | | 6.58 | | ns |
| | | FO = 384 | 4.05 | | 4.59 | | 5.40 | | 7.56 | | ns |
| t _{CKSW} | Maximum Skew | FO = 32 | | 0.38 | | 0.43 | | 0.50 | | 0.70 | ns |
| | | FO = 384 | | 1.73 | | 1.96 | | 2.30 | | 3.22 | ns |
| t _{SUEXT} | Input Latch External Set-Up | FO = 32 | 0.00 | | 0.00 | | 0.00 | | 0.00 | | ns |
| | | FO = 384 | 0.00 | | 0.00 | | 0.00 | | 0.00 | | ns |
| t _{HEXT} | Input Latch External Hold | FO = 32 | 3.08 | | 5.49 | | 4.10 | | 5.74 | | ns |
| | | FO = 384 | 3.53 | | 4.00 | | 4.70 | | 6.58 | | ns |
| t _p | Minimum Period | FO = 32 | 4.65 | | 5.06 | | 5.81 | | 9.69 | | ns |
| | | FO = 384 | 5.12 | | 5.57 | | 6.41 | | 10.68 | | ns |
| f _{MAX} | Maximum Frequency | FO = 32 | | 215.00 | | 197.80 | | 172.00 | | 103.20 | MHz |
| | | FO = 384 | | 195.00 | | 179.40 | | 156.00 | | 93.60 | MHz |

Note:

1. These parameters should be used for estimating device performance. Optimization techniques may further reduce delays by 0 to 4 ns. Routing delays are for typical designs across worst-case operating conditions. Post-route timing analysis or simulation is required to determine actual worst-case performance. Post-route timing is based on actual routing delay measurements performed on the device prior to shipment.

A42MX16 Timing Characteristics (Nominal 5.0V Operation)

(continued)

(Worst-Case Commercial Conditions)

| Output Module Timing | | '-2' Speed | | '-1' Speed | | 'Std' Speed | | '-F' Speed | | |
|--|--|------------|------|------------|-------|-------------|-------|------------|-------|-------|
| Parameter | Description | Min. | Max. | Min. | Max. | Min. | Max. | Min. | Max. | Units |
| TTL Output Module Timing¹ | | | | | | | | | | |
| t _{DLH} | Data-to-Pad HIGH | | 2.79 | | 3.16 | | 3.72 | | 5.21 | ns |
| t _{DHL} | Data-to-Pad LOW | | 3.27 | | 3.71 | | 4.36 | | 6.10 | ns |
| t _{ENZH} | Enable Pad Z to HIGH | | 3.00 | | 3.40 | | 4.00 | | 5.60 | ns |
| t _{ENZL} | Enable Pad Z to LOW | | 3.32 | | 3.76 | | 4.42 | | 6.19 | ns |
| t _{ENHZ} | Enable Pad HIGH to Z | | 6.02 | | 6.82 | | 8.02 | | 11.23 | ns |
| t _{ENLZ} | Enable Pad LOW to Z | | 5.57 | | 6.31 | | 7.42 | | 10.39 | ns |
| t _{GLH} | G-to-Pad HIGH | | 5.63 | | 6.38 | | 7.51 | | 10.51 | ns |
| t _{GHL} | G-to-Pad LOW | | 5.63 | | 6.38 | | 7.51 | | 10.51 | ns |
| t _{LCO} | I/O Latch Clock-to-Out (Pad-to-Pad), 64 Clock Loading | | 6.28 | | 7.12 | | 8.38 | | 11.90 | ns |
| t _{ACO} | Array Clock-to-Out (Pad-to-Pad), 64 Clock Loading | | 8.93 | | 10.12 | | 11.90 | | 16.66 | ns |
| d _{TLH} | Capacitive Loading, LOW to HIGH | | 0.03 | | 0.03 | | 0.04 | | 0.06 | ns/pF |
| d _{THL} | Capacitive Loading, HIGH to LOW | | 0.04 | | 0.04 | | 0.05 | | 0.07 | ns/pF |
| CMOS Output Module Timing¹ | | | | | | | | | | |
| t _{DLH} | Data-to-Pad HIGH | | 3.56 | | 4.03 | | 4.74 | | 6.64 | ns |
| t _{DHL} | Data-to-Pad LOW | | 2.73 | | 3.09 | | 3.64 | | 5.10 | ns |
| t _{ENZH} | Enable Pad Z to HIGH | | 3.00 | | 3.40 | | 4.00 | | 5.60 | ns |
| t _{ENZL} | Enable Pad Z to LOW | | 3.32 | | 3.76 | | 4.42 | | 6.19 | ns |
| t _{ENHZ} | Enable Pad HIGH to Z | | 6.02 | | 6.82 | | 8.02 | | 11.23 | ns |
| t _{ENLZ} | Enable Pad LOW to Z | | 5.57 | | 6.31 | | 7.42 | | 10.39 | ns |
| t _{GLH} | G-to-Pad HIGH | | 5.63 | | 6.38 | | 7.51 | | 10.51 | ns |
| t _{GHL} | G-to-Pad LOW | | 5.63 | | 6.38 | | 7.51 | | 10.51 | ns |
| t _{LCO} | I/O Latch Clock-to-Out (Pad-to-Pad), 64 Clock Loading | | 6.28 | | 7.12 | | 8.38 | | 11.90 | ns |
| t _{ACO} | Array Clock-to-Out (Pad-to-Pad), 64 Clock Loading | | 8.93 | | 10.12 | | 11.90 | | 16.66 | ns |
| d _{TLH} | Capacitive Loading, LOW to HIGH | | 0.03 | | 0.03 | | 0.04 | | 0.06 | ns/pF |
| d _{THL} | Capacitive Loading, HIGH to LOW | | 0.04 | | 0.04 | | 0.05 | | 0.07 | ns/pF |

Notes:

- Delays based on 35 pF loading.

A42MX16 Timing Characteristics (Nominal 3.3V Operation)

(Worst-Case Commercial Conditions, V_{CC} = 3.0V, T_J = 70°C)

| Logic Module Propagation Delays ¹ | | '-2' Speed | | '-1' Speed | | 'Std' Speed | | '-F' Speed | | Units |
|---|--|------------|--------|------------|--------|-------------|-------|------------|-------|-------|
| Parameter | Description | Min. | Max. | Min. | Max. | Min. | Max. | Min. | Max. | |
| t _{PD1} | Single Module | | 2.13 | | 2.42 | | 2.84 | | 3.98 | ns |
| t _{CO} | Sequential Clock-to-Q | | 2.24 | | 2.53 | | 2.98 | | 4.17 | ns |
| t _{GO} | Latch G-to-Q | | 2.13 | | 2.42 | | 2.84 | | 3.98 | ns |
| t _{RS} | Flip-Flop (Latch) Reset-to-Q | | 2.44 | | 2.76 | | 3.25 | | 4.55 | ns |
| Predicted Routing Delays² | | | | | | | | | | |
| t _{RD1} | FO=1 Routing Delay | | 1.21 | | 1.37 | | 1.61 | | 2.25 | ns |
| t _{RD2} | FO=2 Routing Delay | | 1.61 | | 1.82 | | 2.14 | | 3.00 | ns |
| t _{RD3} | FO=3 Routing Delay | | 2.01 | | 2.27 | | 2.67 | | 3.74 | ns |
| t _{RD4} | FO=4 Routing Delay | | 2.40 | | 2.73 | | 3.21 | | 4.49 | ns |
| t _{RD8} | FO=8 Routing Delay | | 4.00 | | 4.53 | | 5.33 | | 7.47 | ns |
| Sequential Timing Characteristics^{3, 4} | | | | | | | | | | |
| t _{SUD} | Flip-Flop (Latch) Data Input Set-Up | 0.50 | | 0.57 | | 0.67 | | 0.94 | | ns |
| t _{HD} | Flip-Flop (Latch) Data Input Hold | 0.00 | | 0.00 | | 0.00 | | 0.00 | | ns |
| t _{SUENA} | Flip-Flop (Latch) Enable Set-Up | 1.05 | | 1.19 | | 1.40 | | 1.96 | | ns |
| t _{HENA} | Flip-Flop (Latch) Enable Hold | 0.00 | | 0.00 | | 0.00 | | 0.00 | | ns |
| t _{WCLKA} | Flip-Flop (Latch) Clock Active Pulse Width | 5.29 | | 6.00 | | 7.06 | | 9.88 | | ns |
| t _{WASYN} | Flip-Flop (Latch) Asynchronous Pulse Width | 6.93 | | 7.85 | | 9.24 | | 12.94 | | ns |
| t _A | Flip-Flop Clock Input Period | 10.58 | | 12.00 | | 14.11 | | 19.76 | | ns |
| t _{INH} | Input Buffer Latch Hold | 0.00 | | 0.00 | | 0.00 | | 0.00 | | ns |
| t _{INSU} | Input Buffer Latch Set-Up | 0.76 | | 0.86 | | 1.01 | | 1.41 | | ns |
| t _{OUTH} | Output Buffer Latch Hold | 0.00 | | 0.00 | | 0.00 | | 0.00 | | ns |
| t _{OUTSU} | Output Buffer Latch Set-Up | 0.76 | | 0.86 | | 1.01 | | 1.41 | | ns |
| f _{MAX} | Flip-Flop (Latch) Clock Frequency | | 117.00 | | 107.64 | | 93.60 | | 56.16 | MHz |

Notes:

- For dual-module macros use t_{PD1} + t_{RD1} + t_{PDn}, t_{CO} + t_{RD1} + t_{PDn}, or t_{PD1} + t_{RD1} + t_{SUD}, whichever is appropriate.
- Routing delays are for typical designs across worst-case operating conditions. These parameters should be used for estimating device performance. Post-route timing analysis or simulation is required to determine actual worst-case performance. Post-route timing is based on actual routing delay measurements performed on the device prior to shipment.
- Data applies to macros based on the S-module. Timing parameters for sequential macros constructed from C-modules can be obtained from the DirectTime Analyzer utility.
- Set-up and hold timing parameters for the input buffer latch are defined with respect to the PAD and the D input. External setup/hold timing parameters must account for delay from an external PAD signal to the G inputs. Delay from an external PAD signal to the G input subtracts (adds) to the internal setup (hold) time.

A42MX16 Timing Characteristics (Nominal 3.3V Operation)

(continued)

(Worst-Case Commercial Conditions)

| Input Module Propagation Delays | | | '-2' Speed | | '-1' Speed | | 'Std' Speed | | '-F' Speed | | |
|--|-----------------------------|----------|------------|--------|------------|--------|-------------|--------|------------|-------|-------|
| Parameter | Description | | Min. | Max. | Min. | Max. | Min. | Max. | Min. | Max. | Units |
| t _{INYH} | Pad-to-Y HIGH | | | 1.64 | | 1.86 | | 2.18 | | 3.06 | ns |
| t _{INYL} | Pad-to-Y LOW | | | 1.26 | | 1.43 | | 1.68 | | 2.35 | ns |
| t _{INGH} | G to Y HIGH | | | 2.18 | | 2.48 | | 2.91 | | 4.08 | ns |
| t _{INGL} | G to Y LOW | | | 2.18 | | 2.48 | | 2.91 | | 4.08 | ns |
| Input Module Predicted Routing Delays ¹ | | | | | | | | | | | |
| t _{IRD1} | FO=1 Routing Delay | | | 2.85 | | 3.22 | | 3.79 | | 5.31 | ns |
| t _{IRD2} | FO=2 Routing Delay | | | 3.24 | | 3.68 | | 4.33 | | 6.06 | ns |
| t _{IRD3} | FO=3 Routing Delay | | | 3.64 | | 4.13 | | 4.86 | | 6.80 | ns |
| t _{IRD4} | FO=4 Routing Delay | | | 4.04 | | 4.58 | | 5.39 | | 7.55 | ns |
| t _{IRD8} | FO=8 Routing Delay | | | 5.64 | | 6.39 | | 7.52 | | 10.53 | ns |
| Global Clock Network | | | | | | | | | | | |
| t _{CKH} | Input LOW to HIGH | FO = 32 | | 6.30 | | 7.14 | | 8.40 | | 11.76 | ns |
| | | FO = 384 | | 7.35 | | 8.33 | | 9.80 | | 13.72 | ns |
| t _{CKL} | Input HIGH to LOW | FO = 32 | | 5.88 | | 6.66 | | 7.84 | | 10.98 | ns |
| | | FO = 384 | | 6.93 | | 7.85 | | 9.24 | | 12.94 | ns |
| t _{PWH} | Minimum Pulse Width HIGH | FO = 32 | 6.30 | | 7.14 | | 8.40 | | 11.76 | | ns |
| | | FO = 384 | 7.35 | | 8.33 | | 9.80 | | 13.72 | | ns |
| t _{PWL} | Minimum Pulse Width LOW | FO = 32 | 5.88 | | 6.66 | | 7.84 | | 10.98 | | ns |
| | | FO = 384 | 6.93 | | 7.85 | | 9.24 | | 12.94 | | ns |
| t _{CKSW} | Maximum Skew | FO = 32 | | 0.53 | | 0.60 | | 0.70 | | 0.98 | ns |
| | | FO = 384 | | 2.42 | | 2.74 | | 3.22 | | 4.51 | ns |
| t _{SUEXT} | Input Latch External Set-Up | FO = 32 | 0.00 | | 0.00 | | 0.00 | | 0.00 | | ns |
| | | FO = 384 | 0.00 | | 0.00 | | 0.00 | | 0.00 | | ns |
| t _{HEXT} | Input Latch External Hold | FO = 32 | 4.31 | | 4.88 | | 5.74 | | 8.04 | | ns |
| | | FO = 384 | 4.94 | | 5.59 | | 6.58 | | 9.21 | | ns |
| t _p | Minimum Period | FO = 32 | 7.75 | | 8.43 | | 9.71 | | 16.15 | | ns |
| | | FO = 384 | 8.55 | | 9.29 | | 10.68 | | 17.81 | | ns |
| f _{MAX} | Maximum Frequency | FO = 32 | | 129.00 | | 118.68 | | 103.20 | | 61.92 | MHz |
| | | FO = 384 | | 117.00 | | 107.64 | | 93.60 | | 56.16 | MHz |

Note:

1. These parameters should be used for estimating device performance. Optimization techniques may further reduce delays by 0 to 4 ns. Routing delays are for typical designs across worst-case operating conditions. Post-route timing analysis or simulation is required to determine actual worst-case performance. Post-route timing is based on actual routing delay measurements performed on the device prior to shipment.



A42MX16 Timing Characteristics (Nominal 3.3V Operation)

(continued)

(Worst-Case Commercial Conditions)

| Output Module Timing | | '-2' Speed | | '-1' Speed | | 'Std' Speed | | '-F' Speed | | |
|--|--|------------|-------|------------|-------|-------------|-------|------------|-------|-------|
| Parameter | Description | Min. | Max. | Min. | Max. | Min. | Max. | Min. | Max. | Units |
| TTL Output Module Timing¹ | | | | | | | | | | |
| t _{DLH} | Data-to-Pad HIGH | | 3.91 | | 4.43 | | 5.21 | | 7.29 | ns |
| t _{DHL} | Data-to-Pad LOW | | 4.58 | | 5.19 | | 6.10 | | 8.55 | ns |
| t _{ENZH} | Enable Pad Z to HIGH | | 4.20 | | 4.76 | | 5.60 | | 7.84 | ns |
| t _{ENZL} | Enable Pad Z to LOW | | 4.64 | | 5.26 | | 6.19 | | 8.66 | ns |
| t _{ENHZ} | Enable Pad HIGH to Z | | 8.42 | | 9.54 | | 11.23 | | 15.72 | ns |
| t _{ENLZ} | Enable Pad LOW to Z | | 7.79 | | 8.83 | | 10.39 | | 14.54 | ns |
| t _{GLH} | G-to-Pad HIGH | | 7.89 | | 8.94 | | 10.51 | | 14.72 | ns |
| t _{GHL} | G-to-Pad LOW | | 7.89 | | 8.94 | | 10.51 | | 14.72 | ns |
| t _{LCO} | I/O Latch Clock-to-Out (Pad-to-Pad), 64 Clock Loading | | 8.93 | | 10.12 | | 11.90 | | 16.66 | ns |
| t _{ACO} | Array Clock-to-Out (Pad-to-Pad), 64 Clock Loading | | 12.50 | | 14.16 | | 16.66 | | 23.32 | ns |
| d _{TLH} | Capacitive Loading, LOW to HIGH | | 0.04 | | 0.05 | | 0.06 | | 0.08 | ns/pF |
| d _{THL} | Capacitive Loading, HIGH to LOW | | 0.05 | | 0.06 | | 0.07 | | 0.10 | ns/pF |
| CMOS Output Module Timing¹ | | | | | | | | | | |
| t _{DLH} | Data-to-Pad HIGH | | 4.98 | | 5.64 | | 6.64 | | 9.29 | ns |
| t _{DHL} | Data-to-Pad LOW | | 3.82 | | 4.33 | | 5.10 | | 7.13 | ns |
| t _{ENZH} | Enable Pad Z to HIGH | | 4.20 | | 4.76 | | 5.60 | | 7.84 | ns |
| t _{ENZL} | Enable Pad Z to LOW | | 4.64 | | 5.26 | | 6.19 | | 8.66 | ns |
| t _{ENHZ} | Enable Pad HIGH to Z | | 8.42 | | 9.54 | | 11.23 | | 15.72 | ns |
| t _{ENLZ} | Enable Pad LOW to Z | | 7.79 | | 8.83 | | 10.39 | | 14.54 | ns |
| t _{GLH} | G-to-Pad HIGH | | 7.89 | | 8.94 | | 10.51 | | 14.72 | ns |
| t _{GHL} | G-to-Pad LOW | | 7.89 | | 8.94 | | 10.51 | | 14.72 | ns |
| t _{LCO} | I/O Latch Clock-to-Out (Pad-to-Pad), 64 Clock Loading | | 8.93 | | 10.12 | | 11.90 | | 16.66 | ns |
| t _{ACO} | Array Clock-to-Out (Pad-to-Pad), 64 Clock Loading | | 12.50 | | 14.16 | | 16.66 | | 23.32 | ns |
| d _{TLH} | Capacitive Loading, LOW to HIGH | | 0.04 | | 0.05 | | 0.06 | | 0.08 | ns/pF |
| d _{THL} | Capacitive Loading, HIGH to LOW | | 0.05 | | 0.06 | | 0.07 | | 0.10 | ns/pF |

Notes:

- Delays based on 35 pF loading.

A42MX24 Timing Characteristics (Nominal 5.0V Operation)

(Worst-Case Commercial Conditions)

| | | Preliminary Information | | | | | | | | |
|--|--|-------------------------|------|------------|------|-------------|------|------------|------|-------|
| Logic Module Propagation Delays ¹ | | '-2 Speed | | '-1' Speed | | 'Std' Speed | | '-F' Speed | | |
| Parameter | Description | Min. | Max. | Min. | Max. | Min. | Max. | Min. | Max. | Units |
| Combinatorial Functions | | | | | | | | | | |
| t _{PD} | Internal Array Module Delay | | 1.31 | | 1.49 | | 1.75 | | 2.45 | ns |
| t _{PDD} | Internal Decode Module Delay | | 1.59 | | 1.80 | | 2.12 | | 2.97 | ns |
| Predicted Routing Delays² | | | | | | | | | | |
| t _{RD1} | FO=1 Routing Delay | | 0.89 | | 1.01 | | 1.19 | | 1.67 | ns |
| t _{RD2} | FO=2 Routing Delay | | 1.15 | | 1.30 | | 1.53 | | 2.14 | ns |
| t _{RD3} | FO=3 Routing Delay | | 1.40 | | 1.59 | | 1.87 | | 2.62 | ns |
| t _{RD4} | FO=4 Routing Delay | | 1.66 | | 1.88 | | 2.21 | | 3.09 | ns |
| t _{RD5} | FO=8 Routing Delay | | 2.67 | | 3.03 | | 3.56 | | 4.98 | ns |
| Sequential Timing Characteristics^{3,4} | | | | | | | | | | |
| t _{CO} | Flip-Flop Clock-to-Output | | 1.43 | | 1.62 | | 1.90 | | 2.66 | ns |
| t _{GO} | Latch Gate-to-Output | | 1.31 | | 1.49 | | 1.75 | | 2.45 | ns |
| t _{SU} | Flip-Flop (Latch) Set-Up Time | 0.35 | | 0.40 | | 0.47 | | 0.66 | | ns |
| t _H | Flip-Flop (Latch) Hold Time | 0.00 | | 0.00 | | 0.00 | | 0.00 | | ns |
| t _{RO} | Flip-Flop (Latch) Reset-to-Output | | 1.55 | | 1.76 | | 2.07 | | 2.90 | ns |
| t _{SUENA} | Flip-Flop (Latch) Enable Set-Up | 0.45 | | 0.51 | | 0.60 | | 0.84 | | ns |
| t _{HENA} | Flip-Flop (Latch) Enable Hold | 0.00 | | 0.00 | | 0.00 | | 0.00 | | ns |
| t _{WCLKA} | Flip-Flop (Latch) Clock Active Pulse Width | 3.68 | | 4.17 | | 4.91 | | 6.87 | | ns |
| t _{WASYN} | Flip-Flop (Latch) Asynchronous Pulse Width | 4.83 | | 5.47 | | 6.44 | | 9.02 | | ns |

Notes:

- For dual-module macros, use $t_{PDI} + t_{RD1} + t_{PDn}$, $t_{CO} + t_{RD1} + t_{PDn}$, or $t_{PDI} + t_{RD1} + t_{SUD}$, whichever is appropriate.
- Routing delays are for typical designs across worst-case operating conditions. These parameters should be used for estimating device performance. Post-route timing analysis or simulation is required to determine actual worst-case performance. Post-route timing is based on actual routing delay measurements performed on the device prior to shipment.
- Data applies to macros based on the S-module. Timing parameters for sequential macros constructed from C-modules can be obtained from the DirectTime Analyzer utility.
- Set-up and hold timing parameters for the Input Buffer Latch are defined with respect to the PAD and the D input. External setup/hold timing parameters must account for delay from an external PAD signal to the G inputs. Delay from an external PAD signal to the G input subtracts (adds) to the internal setup (hold) time.



A42MX24 Timing Characteristics (Nominal 5.0V Operation)

(continued)

(Worst-Case Commercial Conditions)

| | | | Preliminary Information | | | | | | | | |
|--|--------------------------------------|--------|-------------------------|--------|------------|--------|-------------|--------|------------|-------|-------|
| Input Module Propagation Delays | | | '-2' Speed | | '-1' Speed | | 'Std' Speed | | '-F' Speed | | |
| Parameter | Description | | Min. | Max. | Min. | Max. | Min. | Max. | Min. | Max. | Units |
| t _{INPY} | Input Data Pad-to-Y | | | 1.14 | | 1.29 | | 1.52 | | 2.13 | ns |
| t _{INGO} | Input Latch Gate-to-Output | | | 1.39 | | 1.57 | | 1.85 | | 2.59 | ns |
| t _{INH} | Input Latch Hold | | 0.00 | | 0.00 | | 0.00 | | 0.00 | | ns |
| t _{INSU} | Input Latch Set-Up | | 0.53 | | 0.60 | | 0.70 | | 0.98 | | ns |
| t _{ILA} | Latch Active Pulse Width | | 5.18 | | 5.87 | | 6.90 | | 9.66 | | ns |
| Input Module Predicted Routing Delays¹ | | | | | | | | | | | |
| t _{IRD1} | FO=1 Routing Delay | | | 2.03 | | 2.30 | | 2.71 | | 3.79 | ns |
| t _{IRD2} | FO=2 Routing Delay | | | 2.29 | | 2.59 | | 3.05 | | 4.27 | ns |
| t _{IRD3} | FO=3 Routing Delay | | | 2.54 | | 2.88 | | 3.39 | | 4.75 | ns |
| t _{IRD4} | FO=4 Routing Delay | | | 2.80 | | 3.17 | | 3.73 | | 5.22 | ns |
| t _{IRD8} | FO=8 Routing Delay | | | 3.81 | | 4.32 | | 5.08 | | 7.11 | ns |
| Global Clock Network | | | | | | | | | | | |
| t _{CKH} | Input LOW to HIGH | FO=32 | | 4.35 | | 4.93 | | 5.80 | | 8.12 | ns |
| | | FO=486 | | 5.03 | | 5.70 | | 6.70 | | 9.38 | ns |
| t _{CKL} | Input HIGH to LOW | FO=32 | | 4.05 | | 4.59 | | 5.40 | | 7.56 | ns |
| | | FO=486 | | 4.73 | | 5.36 | | 6.30 | | 8.82 | ns |
| t _{PWH} | Minimum Pulse Width HIGH | FO=32 | 2.40 | | 2.72 | | 3.20 | | 4.48 | | ns |
| | | FO=486 | 2.63 | | 2.98 | | 3.50 | | 4.90 | | ns |
| t _{PWL} | Minimum Pulse Width LOW | FO=32 | 2.40 | | 2.72 | | 3.20 | | 4.48 | | ns |
| | | FO=486 | 2.63 | | 2.98 | | 3.50 | | 4.90 | | ns |
| t _{CKSW} | Maximum Skew | FO=32 | | 0.60 | | 0.68 | | 0.80 | | 1.12 | ns |
| | | FO=486 | | 0.60 | | 0.68 | | 0.80 | | 1.12 | ns |
| t _{SUEXT} | Input Latch External Set-Up | FO=32 | 0.00 | | 0.00 | | 0.00 | | 0.00 | | ns |
| | | FO=486 | 0.00 | | 0.00 | | 0.00 | | 0.00 | | ns |
| t _{HEXT} | Input Latch External Hold | FO=32 | 3.08 | | 3.49 | | 4.10 | | 5.74 | | ns |
| | | FO=486 | 3.68 | | 4.17 | | 4.90 | | 6.86 | | ns |
| t _P | Minimum Period (1/f _{MAX}) | FO=32 | 5.23 | | 5.68 | | 6.50 | | 10.89 | | ns |
| | | FO=486 | 5.71 | | 6.21 | | 7.14 | | 11.90 | | ns |
| f _{MAX} | Maximum Datapath Frequency | FO=32 | | 191.25 | | 175.95 | | 153.00 | | 91.80 | MHz |
| | | FO=486 | | 175.00 | | 161.00 | | 140.00 | | 84.00 | MHz |

Note:

1. Routing delays are for typical designs across worst-case operating conditions. These parameters should be used for estimating device performance. Post-route timing analysis or simulation is required to determine actual worst-case performance.

A42MX24 Timing Characteristics (Nominal 5.0V Operation)

(continued)

(Worst-Case Commercial Conditions)

| | | Preliminary Information | | | | | | | | |
|--|--|-------------------------|-------|------------|-------|-------------|-------|------------|-------|-------|
| Output Module Timing | | '-2 Speed | | '-1' Speed | | 'Std' Speed | | '-F' Speed | | |
| Parameter | Description | Min. | Max. | Min. | Max. | Min. | Max. | Min. | Max. | Units |
| TTL Output Module Timing¹ | | | | | | | | | | |
| t _{DLH} | Data-to-Pad HIGH | | 2.70 | | 3.06 | | 3.60 | | 5.04 | ns |
| t _{DHL} | Data-to-Pad LOW | | 3.15 | | 3.57 | | 4.20 | | 5.88 | ns |
| t _{ENZH} | Enable Pad Z to HIGH | | 2.82 | | 3.20 | | 3.76 | | 5.26 | ns |
| t _{ENZL} | Enable Pad Z to LOW | | 3.13 | | 3.54 | | 4.17 | | 5.84 | ns |
| t _{ENHZ} | Enable Pad HIGH to Z | | 5.72 | | 6.48 | | 7.62 | | 10.67 | ns |
| t _{ENLZ} | Enable Pad LOW to Z | | 5.33 | | 6.04 | | 7.10 | | 9.94 | ns |
| t _{GLH} | G-to-Pad HIGH | | 5.42 | | 6.15 | | 7.23 | | 10.12 | ns |
| t _{GHL} | G-to-Pad LOW | | 5.42 | | 6.15 | | 7.23 | | 10.12 | ns |
| t _{LSU} | I/O Latch Output Set-Up | 0.53 | | 0.60 | | 0.70 | | 0.98 | | ns |
| t _{LH} | I/O Latch Output Hold | 0.00 | | 0.00 | | 0.00 | | 0.00 | | ns |
| t _{LCO} | I/O Latch Clock-to-Out (Pad-to-Pad) 32 I/O | | 6.08 | | 6.89 | | 8.10 | | 11.34 | ns |
| t _{ACO} | Array Latch Clock-to-Out (Pad-to-Pad) 32 I/O | | 11.78 | | 13.35 | | 15.70 | | 21.98 | ns |
| d _{TLH} | Capacitive Loading, LOW to HIGH | | 0.04 | | 0.04 | | 0.05 | | 0.07 | ns/pF |
| d _{THL} | Capacitive Loading, HIGH to LOW | | 0.03 | | 0.03 | | 0.04 | | 0.06 | ns/pF |
| CMOS Output Module Timing¹ | | | | | | | | | | |
| t _{DLH} | Data-to-Pad HIGH | | 3.45 | | 3.91 | | 4.60 | | 6.44 | ns |
| t _{DHL} | Data-to-Pad LOW | | 2.61 | | 2.96 | | 3.48 | | 4.87 | ns |
| t _{ENZH} | Enable Pad Z to HIGH | | 2.82 | | 3.20 | | 3.76 | | 5.26 | ns |
| t _{ENZL} | Enable Pad Z to LOW | | 3.13 | | 3.54 | | 4.17 | | 5.84 | ns |
| t _{ENHZ} | Enable Pad HIGH to Z | | 5.72 | | 6.48 | | 7.62 | | 10.67 | ns |
| t _{ENLZ} | Enable Pad LOW to Z | | 5.33 | | 6.04 | | 7.10 | | 9.94 | ns |
| t _{GLH} | G-to-Pad HIGH | | 5.42 | | 6.15 | | 7.23 | | 10.12 | ns |
| t _{GHL} | G-to-Pad LOW | | 5.42 | | 6.15 | | 7.23 | | 10.12 | ns |
| t _{LSU} | I/O Latch Set-Up | 0.53 | | 0.60 | | 0.70 | | 0.98 | | ns |
| t _{LH} | I/O Latch Hold | 0.00 | | 0.00 | | 0.00 | | 0.00 | | ns |
| t _{LCO} | I/O Latch Clock-to-Out (Pad-to-Pad) 32 I/O | | 6.08 | | 6.89 | | 8.10 | | 11.34 | ns |
| t _{ACO} | Array Latch Clock-to-Out (Pad-to-Pad) 32 I/O | | 11.78 | | 13.35 | | 15.70 | | 21.98 | ns |
| d _{TLH} | Capacitive Loading, LOW to HIGH | | 0.04 | | 0.04 | | 0.05 | | 0.07 | ns/pF |
| d _{THL} | Capacitive Loading, HIGH to LOW | | 0.03 | | 0.03 | | 0.04 | | 0.06 | ns/pF |

Notes:

- Delays based on 35 pF loading.



A42MX24 Timing Characteristics (Nominal 3.3V Operation)
(Worst-Case Commercial Conditions)

| | | Preliminary Information | | | | | | | | |
|---|--|-------------------------|------|------------|------|-------------|------|------------|------|-------|
| Logic Module Propagation Delays ¹ | | '-2 Speed | | '-1' Speed | | 'Std' Speed | | '-F' Speed | | |
| Parameter | Description | Min. | Max. | Min. | Max. | Min. | Max. | Min. | Max. | Units |
| Combinatorial Functions | | | | | | | | | | |
| t _{PD} | Internal Array Module Delay | | 1.84 | | 2.08 | | 2.45 | | 3.43 | ns |
| t _{PDD} | Internal Decode Module Delay | | 2.23 | | 2.52 | | 2.97 | | 4.16 | ns |
| Predicted Routing Delays² | | | | | | | | | | |
| t _{RD1} | FO=1 Routing Delay | | 1.25 | | 1.42 | | 1.67 | | 2.33 | ns |
| t _{RD2} | FO=2 Routing Delay | | 1.61 | | 1.82 | | 2.14 | | 3.00 | ns |
| t _{RD3} | FO=3 Routing Delay | | 1.96 | | 2.23 | | 2.62 | | 3.67 | ns |
| t _{RD4} | FO=4 Routing Delay | | 2.32 | | 2.63 | | 3.09 | | 4.33 | ns |
| t _{RD5} | FO=8 Routing Delay | | 3.74 | | 4.24 | | 4.98 | | 6.98 | ns |
| Sequential Timing Characteristics^{3, 4} | | | | | | | | | | |
| t _{CO} | Flip-Flop Clock-to-Output | | 2.00 | | 2.26 | | 2.66 | | 3.72 | ns |
| t _{GO} | Latch Gate-to-Output | | 1.84 | | 2.08 | | 2.45 | | 3.43 | ns |
| t _{SU} | Flip-Flop (Latch) Set-Up Time | 0.49 | | 0.56 | | 0.66 | | 0.92 | | ns |
| t _H | Flip-Flop (Latch) Hold Time | 0.00 | | 0.00 | | 0.00 | | 0.00 | | ns |
| t _{RO} | Flip-Flop (Latch) Reset-to-Output | | 2.17 | | 2.46 | | 2.90 | | 4.06 | ns |
| t _{SUENA} | Flip-Flop (Latch) Enable Set-Up | 0.63 | | 0.71 | | 0.84 | | 1.18 | | ns |
| t _{HENA} | Flip-Flop (Latch) Enable Hold | 0.00 | | 0.00 | | 0.00 | | 0.00 | | ns |
| t _{WCLKA} | Flip-Flop (Latch) Clock Active Pulse Width | 5.16 | | 5.84 | | 6.87 | | 9.62 | | ns |
| t _{WASYN} | Flip-Flop (Latch) Asynchronous Pulse Width | 6.76 | | 7.66 | | 9.02 | | 12.62 | | ns |

Notes:

- For dual-module macros, use $t_{PD1} + t_{RD1} + t_{PDn}$, $t_{CO} + t_{RD1} + t_{PDn}$, or $t_{PD1} + t_{RD1} + t_{SUD}$, whichever is appropriate.
- Routing delays are for typical designs across worst-case operating conditions. These parameters should be used for estimating device performance. Post-route timing analysis or simulation is required to determine actual worst-case performance. Post-route timing is based on actual routing delay measurements performed on the device prior to shipment.
- Data applies to macros based on the S-module. Timing parameters for sequential macros constructed from C-modules can be obtained from the DirectTime Analyzer utility.
- Set-up and hold timing parameters for the Input Buffer Latch are defined with respect to the PAD and the D input. External setup/hold timing parameters must account for delay from an external PAD signal to the G inputs. Delay from an external PAD signal to the G input subtracts (adds) to the internal setup (hold) time.

A42MX24 Timing Characteristics (Nominal 3.3V Operation)

(continued)

(Worst-Case Commercial Conditions)

| | | Preliminary Information | | | | | | | | |
|--|--------------------------------------|-------------------------|--------|------------|--------|-------------|-------|------------|-------|-------|
| Input Module Propagation Delays | | '-2' Speed | | '-1' Speed | | 'Std' Speed | | '-F' Speed | | |
| Parameter | Description | Min. | Max. | Min. | Max. | Min. | Max. | Min. | Max. | Units |
| t _{INPY} | Input Data Pad-to-Y | | 1.60 | | 1.81 | | 2.13 | | 2.98 | ns |
| t _{INGO} | Input Latch Gate-to-Output | | 1.94 | | 2.20 | | 2.59 | | 3.63 | ns |
| t _{INH} | Input Latch Hold | 0.00 | | 0.00 | | 0.00 | | 0.00 | | ns |
| t _{INSU} | Input Latch Set-Up | 0.74 | | 0.83 | | 0.98 | | 1.37 | | ns |
| t _{ILA} | Latch Active Pulse Width | 7.25 | | 8.21 | | 9.66 | | 13.52 | | ns |
| Input Module Predicted Routing Delays¹ | | | | | | | | | | |
| t _{IRD1} | FO=1 Routing Delay | | 2.85 | | 3.22 | | 3.79 | | 5.31 | ns |
| t _{IRD2} | FO=2 Routing Delay | | 3.20 | | 3.63 | | 4.27 | | 5.98 | ns |
| t _{IRD3} | FO=3 Routing Delay | | 3.56 | | 4.03 | | 4.75 | | 6.64 | ns |
| t _{IRD4} | FO=4 Routing Delay | | 3.92 | | 4.44 | | 5.22 | | 7.31 | ns |
| t _{IRD8} | FO=8 Routing Delay | | 5.33 | | 6.05 | | 7.11 | | 9.96 | ns |
| Global Clock Network | | | | | | | | | | |
| t _{CKH} | Input LOW to HIGH | | 6.09 | | 6.90 | | 8.12 | | 11.37 | ns |
| | | | 7.04 | | 7.97 | | 9.38 | | 13.13 | ns |
| t _{CKL} | Input HIGH to LOW | | 5.67 | | 6.43 | | 7.56 | | 10.58 | ns |
| | | | 6.62 | | 7.50 | | 8.82 | | 12.35 | ns |
| t _{PWH} | Minimum Pulse Width HIGH | | | 3.81 | | 4.48 | | 6.27 | | ns |
| | | | 3.36 | 4.17 | | 4.90 | | 6.86 | | ns |
| t _{PWL} | Minimum Pulse Width LOW | | | 3.81 | | 4.48 | | 6.27 | | ns |
| | | | 3.36 | 4.17 | | 4.90 | | 6.86 | | ns |
| t _{CKSW} | Maximum Skew | | 0.84 | | 0.95 | | 1.12 | | 1.57 | ns |
| | | | 0.84 | | 0.95 | | 1.12 | | 1.57 | ns |
| t _{SUEXT} | Input Latch External Set-Up | | 0.00 | | 0.00 | | 0.00 | | 0.00 | ns |
| | | | 0.00 | | 0.00 | | 0.00 | | 0.00 | ns |
| t _{HEXT} | Input Latch External Hold | | 4.31 | | 4.88 | | 5.74 | | 8.04 | ns |
| | | | 5.15 | | 5.83 | | 6.86 | | 9.60 | ns |
| t _p | Minimum Period (1/f _{MAX}) | | 8.71 | | 9.47 | | 10.80 | | 18.15 | ns |
| | | | 9.52 | | 10.35 | | 11.90 | | 19.84 | ns |
| f _{MAX} | Maximum Datapath Frequency | | 114.75 | | 105.57 | | 91.80 | | 55.08 | MHz |
| | | | 105.00 | | 96.60 | | 84.00 | | 50.40 | MHz |

Note:

1. Routing delays are for typical designs across worst-case operating conditions. These parameters should be used for estimating device performance. Post-route timing analysis or simulation is required to determine actual worst-case performance.



A42MX24 Timing Characteristics (Nominal 3.3V Operation)

(continued)

(Worst-Case Commercial Conditions)

| Output Module Timing | | Preliminary Information | | | | | | | | Units |
|--|---|-------------------------|-------|------------|-------|-------------|-------|------------|-------|-------|
| | | '-2' Speed | | '-1' Speed | | 'Std' Speed | | '-F' Speed | | |
| Parameter | Description | Min. | Max. | Min. | Max. | Min. | Max. | Min. | Max. | Units |
| TTL Output Module Timing¹ | | | | | | | | | | |
| t _{DLH} | Data-to-Pad HIGH | | 3.78 | | 4.28 | | 5.04 | | 7.06 | ns |
| t _{DHL} | Data-to-Pad LOW | | 4.41 | | 5.00 | | 5.88 | | 8.23 | ns |
| t _{ENZH} | Enable Pad Z to HIGH | | 3.95 | | 4.47 | | 5.26 | | 7.37 | ns |
| t _{ENZL} | Enable Pad Z to LOW | | 4.38 | | 4.96 | | 5.84 | | 8.17 | ns |
| t _{ENHZ} | Enable Pad HIGH to Z | | 8.00 | | 9.07 | | 10.67 | | 14.94 | ns |
| t _{ENLZ} | Enable Pad LOW to Z | | 7.46 | | 8.45 | | 9.94 | | 13.92 | ns |
| t _{GLH} | G-to-Pad HIGH | | 7.59 | | 8.60 | | 10.12 | | 14.17 | ns |
| t _{GHL} | G-to-Pad LOW | | 7.59 | | 8.60 | | 10.12 | | 14.17 | ns |
| t _{LSU} | I/O Latch Output Set-Up | 0.74 | | 0.83 | | 0.98 | | 1.37 | | ns |
| t _{LH} | I/O Latch Output Hold | 0.00 | | 0.00 | | 0.00 | | 0.00 | | ns |
| t _{LCO} | I/O Latch Clock-to-Out (Pad-to-Pad) 32 I/O | | 8.51 | | 9.64 | | 11.34 | | 15.88 | ns |
| t _{ACO} | Array Latch Clock-to-Out (Pad-to-Pad) 32 I/O | | 16.49 | | 18.68 | | 21.98 | | 30.77 | ns |
| d _{TLH} | Capacitive Loading, LOW to HIGH | | 0.05 | | 0.06 | | 0.07 | | 0.10 | ns/pF |
| d _{THL} | Capacitive Loading, HIGH to LOW | | 0.04 | | 0.05 | | 0.06 | | 0.08 | ns/pF |
| CMOS Output Module Timing¹ | | | | | | | | | | |
| t _{DLH} | Data-to-Pad HIGH | | 5.32 | | 5.47 | | 6.44 | | 9.02 | ns |
| t _{DHL} | Data-to-Pad LOW | | 3.90 | | 4.14 | | 4.87 | | 6.82 | ns |
| t _{ENZH} | Enable Pad Z to HIGH | | 3.95 | | 4.47 | | 5.26 | | 7.37 | ns |
| t _{ENZL} | Enable Pad Z to LOW | | 3.75 | | 4.96 | | 5.84 | | 8.17 | ns |
| t _{ENHZ} | Enable Pad HIGH to Z | | 8.00 | | 9.07 | | 10.67 | | 14.94 | ns |
| t _{ENLZ} | Enable Pad LOW to Z | | 7.46 | | 8.45 | | 9.94 | | 13.92 | ns |
| t _{GLH} | G-to-Pad HIGH | | 7.59 | | 8.60 | | 10.12 | | 14.17 | ns |
| t _{GHL} | G-to-Pad LOW | | 7.59 | | 8.60 | | 10.12 | | 14.17 | ns |
| t _{LSU} | I/O Latch Set-Up | 0.74 | | 0.83 | | 0.98 | | 1.37 | | ns |
| t _{LH} | I/O Latch Hold | 0.00 | | 0.00 | | 0.00 | | 0.00 | | ns |
| t _{LCO} | I/O Latch Clock-to-Out (Pad-to-Pad) 32 I/O | | 8.51 | | 9.64 | | 11.34 | | 15.88 | ns |
| t _{ACO} | Array Latch Clock-to-Out (Pad-to-Pad) 32 I/O | | 16.49 | | 18.68 | | 21.98 | | 30.77 | ns |
| d _{TLH} | Capacitive Loading, LOW to HIGH | | 0.05 | | 0.06 | | 0.07 | | 0.10 | ns/pF |
| d _{THL} | Capacitive Loading, HIGH to LOW | | 0.04 | | 0.05 | | 0.06 | | 0.08 | ns/pF |

Notes:

- Delays based on 35 pF loading.

A42MX36 Timing Characteristics (Nominal 5.0V Operation)

(Worst-Case Commercial Conditions)

| | | Preliminary Information | | | | | | | | |
|--|--|-------------------------|------|------------|------|-------------|------|------------|------|-------|
| Logic Module Propagation Delays | | '-2' Speed | | '-1' Speed | | 'Std' Speed | | '-F' Speed | | |
| Parameter | Description | Min. | Max. | Min. | Max. | Min. | Max. | Min. | Max. | Units |
| Combinatorial Functions | | | | | | | | | | |
| t_{PD} | Internal Array Module Delay | | 1.46 | | 1.66 | | 1.95 | | 2.73 | ns |
| t_{PDD} | Internal Decode Module Delay | | 1.78 | | 2.01 | | 2.37 | | 3.32 | ns |
| Predicted Module Routing Delays | | | | | | | | | | |
| t_{RD1} | FO=1 Routing Delay | | 1.04 | | 1.18 | | 1.39 | | 1.95 | ns |
| t_{RD2} | FO=2 Routing Delay | | 1.42 | | 1.61 | | 1.89 | | 2.65 | ns |
| t_{RD3} | FO=3 Routing Delay | | 1.79 | | 2.03 | | 2.39 | | 3.35 | ns |
| t_{RD4} | FO=4 Routing Delay | | 2.18 | | 2.47 | | 2.90 | | 4.06 | ns |
| t_{RD5} | FO=8 Routing Delay | | 3.68 | | 4.17 | | 4.91 | | 6.87 | ns |
| t_{RDD} | Decode-to-Output Routing Delay | | 0.38 | | 0.43 | | 0.50 | | 0.70 | ns |
| Sequential Timing Characteristics | | | | | | | | | | |
| t_{CO} | Flip-Flop Clock-to-Output | | 1.43 | | 1.62 | | 1.90 | | 2.66 | ns |
| t_{GO} | Latch Gate-to-Output | | 1.43 | | 1.62 | | 1.90 | | 2.66 | ns |
| t_{SU} | Flip-Flop (Latch) Set-Up Time | 0.35 | | 0.40 | | 0.47 | | 0.66 | | ns |
| t_H | Flip-Flop (Latch) Hold Time | 0.00 | | 0.00 | | 0.00 | | 0.00 | | ns |
| t_{RO} | Flip-Flop (Latch) Reset-to-Output | | 1.73 | | 1.96 | | 2.31 | | 3.23 | ns |
| t_{SUENA} | Flip-Flop (Latch) Enable Set-Up | 0.75 | | 0.85 | | 1.00 | | 1.40 | | ns |
| t_{HENA} | Flip-Flop (Latch) Enable Hold | 0.00 | | 0.00 | | 0.00 | | 0.00 | | ns |
| t_{WCLKA} | Flip-Flop (Latch) Clock Active Pulse Width | 3.68 | | 4.17 | | 4.91 | | 6.87 | | ns |
| t_{WASYN} | Flip-Flop (Latch) Asynchronous Pulse Width | 4.83 | | 5.47 | | 6.44 | | 9.02 | | ns |



A42MX36 Timing Characteristics (Nominal 5.0V Operation)

(continued)

(Worst-Case Commercial Conditions)

| | | Preliminary Information | | | | | | | | |
|-------------------------------------|-------------------------------------|-------------------------|------|------------|-------|-------------|-------|------------|-------|-------|
| Logic Module Timing | | '-2 Speed | | '-1' Speed | | 'Std' Speed | | '-F' Speed | | |
| Parameter | Description | Min. | Max. | Min. | Max. | Min. | Max. | Min. | Max. | Units |
| Synchronous SRAM Operations | | | | | | | | | | |
| t _{RC} | Read Cycle Time | 7.50 | | 8.50 | | 10.00 | | 14.00 | | ns |
| t _{WC} | Write Cycle Time | 7.50 | | 8.50 | | 10.00 | | 14.00 | | ns |
| t _{RCKHL} | Clock HIGH/LOW Time | 3.75 | | 4.25 | | 5.00 | | 7.00 | | ns |
| t _{RCD} | Data Valid After Clock HIGH/LOW | | 3.75 | | 4.25 | | 5.00 | | 7.00 | ns |
| t _{ADSU} | Address/Data Set-Up Time | 1.80 | | 2.04 | | 2.40 | | 3.36 | | ns |
| t _{ADH} | Address/Data Hold Time | 0.00 | | 0.00 | | 0.00 | | 0.00 | | ns |
| t _{RENSU} | Read Enable Set-Up | 0.68 | | 0.77 | | 0.90 | | 1.26 | | ns |
| t _{RENH} | Read Enable Hold | 3.75 | | 4.25 | | 5.00 | | 7.00 | | ns |
| t _{WENSU} | Write Enable Set-Up | 3.00 | | 3.40 | | 4.00 | | 5.60 | | ns |
| t _{WENH} | Write Enable Hold | 0.00 | | 0.00 | | 0.00 | | 0.00 | | ns |
| t _{BENS} | Block Enable Set-Up | 3.08 | | 3.49 | | 4.10 | | 5.74 | | ns |
| t _{BENH} | Block Enable Hold | 0.00 | | 0.00 | | 0.00 | | 0.00 | | ns |
| Asynchronous SRAM Operations | | | | | | | | | | |
| t _{RPD} | Asynchronous Access Time | | 9.00 | | 10.20 | | 12.00 | | 16.80 | ns |
| t _{RDADV} | Read Address Valid | 9.75 | | 11.10 | | 13.00 | | 18.20 | | ns |
| t _{ADSU} | Address/Data Set-Up Time | 1.80 | | 2.04 | | 2.40 | | 3.36 | | ns |
| t _{ADH} | Address/Data Hold Time | 0.00 | | 0.00 | | 0.00 | | 0.00 | | ns |
| t _{RENSUA} | Read Enable Set-Up to Address Valid | 0.68 | | 0.77 | | 0.90 | | 1.26 | | ns |
| t _{RENHA} | Read Enable Hold | 3.75 | | 4.25 | | 5.00 | | 7.00 | | ns |
| t _{WENSU} | Write Enable Set-Up | 3.00 | | 3.40 | | 4.00 | | 5.60 | | ns |
| t _{WENH} | Write Enable Hold | 0.00 | | 0.00 | | 0.00 | | 0.00 | | ns |
| t _{DOH} | Data Out Hold Time | | 1.35 | | 1.53 | | 1.80 | | 2.52 | ns |

A42MX36 Timing Characteristics (Nominal 5.0V Operation)
(Worst-Case Commercial Conditions)

(continued)

| | | Advanced Information | | | | | | | | | |
|---------------------------------------|---|----------------------|------|------------|------|-------------|------|------------|-------|-------|-----|
| Input Module Propagation Delays | | '-2' Speed | | '-1' Speed | | 'Std' Speed | | '-F' Speed | | | |
| Parameter | Description | Min. | Max. | Min. | Max. | Min. | Max. | Min. | Max. | Units | |
| t _{INPY} | Input Data Pad-to-Y | | 1.14 | | 1.29 | | 1.52 | | 2.13 | ns | |
| t _{INGO} | Input Latch Gate-to-Output ¹ | | 1.55 | | 1.76 | | 2.07 | | 2.90 | ns | |
| t _{INH} | Input Latch Hold ¹ | 0.00 | | 0.00 | | 0.00 | | 0.00 | | ns | |
| t _{INSU} | Input Latch Set-Up ¹ | 0.53 | | 0.60 | | 0.70 | | 0.98 | | ns | |
| t _{ILA} | Latch Active Pulse Width ¹ | 5.18 | | 5.87 | | 6.90 | | 9.66 | | ns | |
| Input Module Predicted Routing Delays | | | | | | | | | | | |
| t _{IRD1} | FO=1 Routing Delay | | 2.18 | | 2.47 | | 2.91 | | 4.07 | ns | |
| t _{IRD2} | FO=2 Routing Delay | | 2.56 | | 2.90 | | 3.41 | | 4.77 | ns | |
| t _{IRD3} | FO=3 Routing Delay | | 2.93 | | 3.32 | | 3.91 | | 5.47 | ns | |
| t _{IRD4} | FO=4 Routing Delay | | 3.32 | | 3.76 | | 4.42 | | 6.19 | ns | |
| t _{IRD8} | FO=8 Routing Delay | | 4.82 | | 5.47 | | 6.43 | | 9.00 | ns | |
| Global Clock Network | | | | | | | | | | | |
| t _{CKH} | Input LOW to HIGH | FO=32 | 4.35 | | 4.93 | | 5.80 | | 8.12 | ns | |
| | | FO=635 | 5.63 | | 6.38 | | 7.50 | | 10.50 | ns | |
| t _{CKL} | Input HIGH to LOW | FO=32 | 4.20 | | 4.76 | | 5.60 | | 7.81 | ns | |
| | | FO=635 | 5.40 | | 6.12 | | 7.20 | | 10.08 | ns | |
| t _{PWH} | Minimum Pulse Width HIGH | FO=32 | 1.95 | | 2.21 | | 2.60 | | 3.64 | ns | |
| | | FO=635 | 2.18 | | 2.47 | | 2.90 | | 4.06 | ns | |
| t _{PWL} | Minimum Pulse Width LOW | FO=32 | 1.95 | | 2.21 | | 2.60 | | 3.64 | ns | |
| | | FO=635 | 2.18 | | 2.47 | | 2.90 | | 4.06 | ns | |
| t _{CKSW} | Maximum Skew | FO=32 | | 0.83 | | 0.94 | | 1.00 | | 1.40 | ns |
| | | FO=635 | | 0.83 | | 0.94 | | 1.00 | | 1.40 | ns |
| t _{SUEXT} | Input Latch External Set-Up | FO=32 | 0.00 | | 0.00 | | 0.00 | | 0.00 | ns | |
| | | FO=635 | 0.00 | | 0.00 | | 0.00 | | 0.00 | ns | |
| t _{HEXT} | Input Latch External Hold | FO=32 | 3.15 | | 3.57 | | 4.20 | | 5.88 | ns | |
| | | FO=635 | 3.68 | | 4.17 | | 4.90 | | 6.86 | ns | |
| t _p | Minimum Period (1/f _{MAX}) | FO=32 | 6.10 | | 6.64 | | 7.63 | | 12.72 | ns | |
| | | FO=635 | 6.61 | | 7.19 | | 8.26 | | 13.77 | ns | |
| f _{HMAX} | Maximum Datapath Frequency | FO=32 | | 163.75 | | 150.65 | | 131.00 | | 78.60 | MHz |
| | | FO=635 | | 151.25 | | 139.15 | | 121.00 | | 72.60 | MHz |

Note:

1. Routing delays are for typical designs across worst-case operating conditions. These parameters should be used for estimating device performance. Post-route timing analysis or simulation is required to determine actual worst-case performance.



A42MX36 Timing Characteristics (Nominal 5.0V Operation)

(continued)

(Worst-Case, Commercial Conditions)

| | | Advanced Information | | | | | | | | |
|--|---|----------------------|------|------------|------|-------------|-------|------------|-------|-------|
| Output Module Timing | | '-2' Speed | | '-1' Speed | | 'Std' Speed | | '-F' Speed | | |
| Parameter | Description | Min. | Max. | Min. | Max. | Min. | Max. | Min. | Max. | Units |
| TTL Output Module Timing¹ | | | | | | | | | | |
| t _{DLH} | Data-to-Pad HIGH | | 2.84 | | 3.21 | | 3.78 | | 5.29 | ns |
| t _{DHL} | Data-to-Pad LOW | | 3.29 | | 3.73 | | 4.39 | | 6.15 | ns |
| t _{ENZH} | Enable Pad Z to HIGH | | 2.95 | | 3.34 | | 3.93 | | 5.50 | ns |
| t _{ENZL} | Enable Pad Z to LOW | | 3.26 | | 3.69 | | 4.34 | | 6.08 | ns |
| t _{ENHZ} | Enable Pad HIGH to Z | | 5.84 | | 6.62 | | 7.79 | | 10.91 | ns |
| t _{ENLZ} | Enable Pad LOW to Z | | 5.45 | | 6.18 | | 7.27 | | 10.18 | ns |
| t _{GLH} | G-to-Pad HIGH | | 5.59 | | 6.33 | | 7.45 | | 10.43 | ns |
| t _{GHL} | G-to-Pad LOW | | 5.59 | | 6.33 | | 7.45 | | 10.43 | ns |
| t _{LSU} | I/O Latch Output Set-Up | 0.53 | | 0.60 | | 0.70 | | 0.98 | | ns |
| t _{LH} | I/O Latch Output Hold | 0.00 | | 0.00 | | 0.00 | | 0.00 | | ns |
| t _{LCO} | I/O Latch Clock-to-Out (Pad-to-Pad) 32 I/O | | 6.30 | | 7.14 | | 8.40 | | 11.76 | ns |
| t _{ACO} | Array Latch Clock-to-Out (Pad-to-Pad) 32 I/O | | 8.63 | | 9.78 | | 11.50 | | 16.10 | ns |
| d _{TLH} | Capacitive Loading, LOW to HIGH | | 0.08 | | 0.09 | | 0.10 | | 0.14 | ns/pF |
| d _{THL} | Capacitive Loading, HIGH to LOW | | 0.08 | | 0.09 | | 0.10 | | 0.14 | ns/pF |
| CMOS Output Module Timing¹ | | | | | | | | | | |
| t _{DLH} | Data-to-Pad HIGH | | 3.92 | | 4.45 | | 5.23 | | 7.32 | ns |
| t _{DHL} | Data-to-Pad LOW | | 2.73 | | 3.09 | | 3.64 | | 5.10 | ns |
| t _{ENZH} | Enable Pad Z to HIGH | | 2.95 | | 3.34 | | 3.93 | | 5.50 | ns |
| t _{ENZL} | Enable Pad Z to LOW | | 3.26 | | 3.69 | | 4.34 | | 6.08 | ns |
| t _{ENHZ} | Enable Pad HIGH to Z | | 5.84 | | 6.62 | | 7.79 | | 10.91 | ns |
| t _{ENLZ} | Enable Pad LOW to Z | | 5.45 | | 6.18 | | 7.27 | | 10.19 | ns |
| t _{GLH} | G-to-Pad HIGH | | 5.59 | | 6.33 | | 7.45 | | 10.43 | ns |
| t _{GHL} | G-to-Pad LOW | | 5.59 | | 6.33 | | 7.45 | | 10.43 | ns |
| t _{LSU} | I/O Latch Set-Up | 0.53 | | 0.60 | | 0.70 | | 0.98 | | ns |
| t _{LH} | I/O Latch Hold | 0.00 | | 0.00 | | 0.00 | | 0.00 | | ns |
| t _{LCO} | I/O Latch Clock-to-Out (Pad-to-Pad) 32 I/O | | 6.30 | | 7.14 | | 8.40 | | 11.76 | ns |
| t _{ACO} | Array Latch Clock-to-Out (Pad-to-Pad) 32 I/O | | 8.63 | | 9.78 | | 11.50 | | 16.10 | ns |
| d _{TLH} | Capacitive Loading, LOW to HIGH | | 0.08 | | 0.09 | | 0.10 | | 0.14 | ns/pF |
| d _{THL} | Capacitive Loading, HIGH to LOW | | 0.08 | | 0.09 | | 0.10 | | 0.14 | ns/pF |

Notes:

1. Routing delays are for typical designs across worst-case operating conditions. These parameters should be used for estimating device performance. Post-route timing analysis or simulation is required to determine actual worst-case performance.

A42MX36 Timing Characteristics (Nominal 3.3V Operation)

(Worst-Case Commercial Conditions)

| | | Preliminary Information | | | | | | | | |
|--|--|-------------------------|------|------------|------|-------------|------|------------|------|-------|
| Logic Module Propagation Delays | | '-2 Speed | | '-1' Speed | | 'Std' Speed | | '-F' Speed | | |
| Parameter | Description | Min. | Max. | Min. | Max. | Min. | Max. | Min. | Max. | Units |
| Combinatorial Functions | | | | | | | | | | |
| t _{PD} | Internal Array Module Delay | | 2.05 | | 2.32 | | 2.73 | | 3.82 | ns |
| t _{PDD} | Internal Decode Module Delay | | 2.49 | | 2.82 | | 3.32 | | 4.65 | ns |
| Predicted Module Routing Delays | | | | | | | | | | |
| t _{RD1} | FO=1 Routing Delay | | 1.46 | | 1.65 | | 1.95 | | 2.72 | ns |
| t _{RD2} | FO=2 Routing Delay | | 1.98 | | 2.25 | | 2.65 | | 3.70 | ns |
| t _{RD3} | FO=3 Routing Delay | | 2.51 | | 2.84 | | 3.35 | | 4.68 | ns |
| t _{RD4} | FO=4 Routing Delay | | 3.05 | | 3.45 | | 4.06 | | 5.68 | ns |
| t _{RD5} | FO=8 Routing Delay | | 5.16 | | 5.84 | | 6.87 | | 9.62 | ns |
| t _{RDD} | Decode-to-Output Routing Delay | | 0.53 | | 0.60 | | 0.70 | | 0.98 | ns |
| Sequential Timing Characteristics | | | | | | | | | | |
| t _{CO} | Flip-Flop Clock-to-Output | | 2.00 | | 2.26 | | 2.66 | | 3.72 | ns |
| t _{GO} | Latch Gate-to-Output | | 2.00 | | 2.26 | | 2.66 | | 3.72 | ns |
| t _{SU} | Flip-Flop (Latch) Set-Up Time | 0.49 | | 0.56 | | 0.66 | | 0.92 | | ns |
| t _H | Flip-Flop (Latch) Hold Time | 0.00 | | 0.00 | | 0.00 | | 0.00 | | ns |
| t _{RO} | Flip-Flop (Latch) Reset-to-Output | | 2.43 | | 2.75 | | 3.23 | | 4.53 | ns |
| t _{SUENA} | Flip-Flop (Latch) Enable Set-Up | 1.05 | | 1.19 | | 1.40 | | 1.96 | | ns |
| t _{HENA} | Flip-Flop (Latch) Enable Hold | 0.00 | | 0.00 | | 0.00 | | 0.00 | | ns |
| t _{WCLKA} | Flip-Flop (Latch) Clock Active Pulse Width | 5.16 | | 5.84 | | 6.87 | | 9.62 | | ns |
| t _{WASYN} | Flip-Flop (Latch) Asynchronous Pulse Width | 6.76 | | 7.66 | | 9.02 | | 12.62 | | ns |



A42MX36 Timing Characteristics (Nominal 3.3V Operation)

(continued)

(Worst-Case Commercial Conditions)

| | | Preliminary Information | | | | | | | | |
|-------------------------------------|-------------------------------------|-------------------------|-------|------------|-------|-------------|-------|------------|-------|-------|
| Logic Module Timing | | '-2 Speed | | '-1' Speed | | 'Std' Speed | | '-F' Speed | | |
| Parameter | Description | Min. | Max. | Min. | Max. | Min. | Max. | Min. | Max. | Units |
| Synchronous SRAM Operations | | | | | | | | | | |
| t _{RC} | Read Cycle Time | 10.50 | | 11.90 | | 14.00 | | 19.60 | | ns |
| t _{WC} | Write Cycle Time | 10.50 | | 11.90 | | 14.00 | | 19.60 | | ns |
| t _{RCKHL} | Clock HIGH/LOW Time | 5.30 | | 6.00 | | 7.00 | | 9.80 | | ns |
| t _{RCO} | Data Valid After Clock HIGH/LOW | | 5.30 | | 6.00 | | 7.00 | | 9.80 | ns |
| t _{ADSU} | Address/Data Set-Up Time | 2.50 | | 2.80 | | 3.40 | | 4.80 | | ns |
| t _{ADH} | Address/Data Hold Time | 0.00 | | 0.00 | | 0.00 | | 0.00 | | ns |
| t _{RENSU} | Read Enable Set-Up | 12.00 | | 1.10 | | 1.30 | | 1.80 | | ns |
| t _{RENH} | Read Enable Hold | 5.30 | | 6.00 | | 7.00 | | 9.80 | | ns |
| t _{WENSU} | Write Enable Set-Up | 4.20 | | 4.80 | | 5.60 | | 7.80 | | ns |
| t _{WENH} | Write Enable Hold | 0.00 | | 0.00 | | 0.00 | | 0.00 | | ns |
| t _{BENS} | Block Enable Set-Up | 4.30 | | 4.90 | | 5.70 | | 8.00 | | ns |
| t _{BENH} | Block Enable Hold | 0.00 | | 0.00 | | 0.00 | | 0.00 | | ns |
| Asynchronous SRAM Operations | | | | | | | | | | |
| t _{RPD} | Asynchronous Access Time | | 12.60 | | 14.30 | | 16.80 | | 23.50 | ns |
| t _{RDADV} | Read Address Valid | 13.70 | | 15.50 | | 18.20 | | 25.50 | | ns |
| t _{ADSU} | Address/Data Set-Up Time | 2.50 | | 2.80 | | 3.40 | | 4.76 | | ns |
| t _{ADH} | Address/Data Hold Time | 0.00 | | 0.00 | | 0.00 | | 0.00 | | ns |
| t _{RENSUA} | Read Enable Set-Up to Address Valid | 1.00 | | 1.10 | | 1.30 | | 1.80 | | ns |
| t _{RENHA} | Read Enable Hold | 5.30 | | 6.00 | | 7.00 | | 9.80 | | ns |
| t _{WENSU} | Write Enable Set-Up | 4.20 | | 4.80 | | 5.60 | | 7.80 | | ns |
| t _{WENH} | Write Enable Hold | 0.00 | | 0.00 | | 0.00 | | 0.00 | | ns |
| t _{DOH} | Data Out Hold Time | | 2.00 | | 2.10 | | 2.50 | | 3.50 | ns |

A42MX36 Timing Characteristics (Nominal 3.3V Operation)

(continued)

(Worst-Case Commercial Conditions)

| | | Preliminary Information | | | | | | | | | |
|---------------------------------------|---|-------------------------|-------|------------|-------|-------------|-------|------------|-------|-------|-----|
| Input Module Propagation Delays | | '-2' Speed | | '-1' Speed | | 'Std' Speed | | '-F' Speed | | | |
| Parameter | Description | Min. | Max. | Min. | Max. | Min. | Max. | Min. | Max. | Units | |
| t _{INPY} | Input Data Pad-to-Y | | 1.60 | | 1.81 | | 2.13 | | 2.98 | ns | |
| t _{INGO} | Input Latch Gate-to-Output ¹ | | 2.17 | | 2.46 | | 2.90 | | 4.06 | ns | |
| t _{INH} | Input Latch Hold ¹ | 0.00 | | 0.00 | | 0.00 | | 0.00 | | ns | |
| t _{INSU} | Input Latch Set-Up ¹ | 0.74 | | 0.83 | | 0.98 | | 1.37 | | ns | |
| t _{ILA} | Latch Active Pulse Width ¹ | 7.25 | | 8.21 | | 9.66 | | 13.52 | | ns | |
| Input Module Predicted Routing Delays | | | | | | | | | | | |
| t _{IRD1} | FO=1 Routing Delay | | 3.06 | | 3.46 | | 4.07 | | 5.70 | ns | |
| t _{IRD2} | FO=2 Routing Delay | | 3.58 | | 4.06 | | 4.77 | | 6.68 | ns | |
| t _{IRD3} | FO=3 Routing Delay | | 4.11 | | 4.65 | | 5.47 | | 7.66 | ns | |
| t _{IRD4} | FO=4 Routing Delay | | 4.64 | | 5.26 | | 6.19 | | 8.66 | ns | |
| t _{IRD8} | FO=8 Routing Delay | | 6.75 | | 7.65 | | 9.00 | | 12.60 | ns | |
| Global Clock Network | | | | | | | | | | | |
| t _{CKH} | Input LOW to HIGH | FO=32 | 6.09 | | 6.90 | | 8.12 | | 11.37 | ns | |
| | | FO=635 | 7.88 | | 8.93 | | 10.50 | | 14.70 | ns | |
| t _{CKL} | Input HIGH to LOW | FO=32 | 5.88 | | 6.66 | | 7.84 | | 10.98 | ns | |
| | | FO=635 | 7.56 | | 8.57 | | 10.08 | | 14.11 | ns | |
| t _{PWH} | Minimum Pulse Width HIGH | FO=32 | 2.73 | | 3.09 | | 3.64 | | 5.10 | ns | |
| | | FO=635 | 3.05 | | 3.45 | | 4.06 | | 5.68 | ns | |
| t _{PWL} | Minimum Pulse Width LOW | FO=32 | 2.73 | | 3.09 | | 3.64 | | 5.10 | ns | |
| | | FO=635 | 3.05 | | 3.45 | | 4.06 | | 5.68 | ns | |
| t _{CKSW} | Maximum Skew | FO=32 | | 1.16 | | 1.31 | | 1.54 | | 2.16 | ns |
| | | FO=635 | | 1.16 | | 1.31 | | 1.54 | | 2.16 | ns |
| t _{SUEXT} | Input Latch External Set-Up | FO=32 | 0.00 | | 0.00 | | 0.00 | | 0.00 | ns | |
| | | FO=635 | 0.00 | | 0.00 | | 0.00 | | 0.00 | ns | |
| t _{HEXT} | Input Latch External Hold | FO=32 | 4.41 | | 5.00 | | 5.88 | | 8.23 | ns | |
| | | FO=635 | 5.15 | | 5.83 | | 6.86 | | 9.60 | ns | |
| t _p | Minimum Period (1/f _{MAX}) | FO=32 | 10.18 | | 11.06 | | 12.70 | | 21.20 | ns | |
| | | FO=635 | 11.02 | | 11.98 | | 13.77 | | 22.96 | ns | |
| f _{HMAX} | Maximum Datapath Frequency | FO=32 | | 98.25 | | 90.39 | | 78.60 | | 47.16 | MHz |
| | | FO=635 | | 90.75 | | 83.49 | | 72.60 | | 43.56 | MHz |

Note:

1. Routing delays are for typical designs across worst-case operating conditions. These parameters should be used for estimating device performance. Post-route timing analysis or simulation is required to determine actual worst-case performance.



A42MX36 Timing Characteristics (Nominal 3.3V Operation)

(continued)

(Worst-Case Commercial Conditions)

| | | Preliminary Information | | | | | | | | |
|--|---|-------------------------|-------|------------|-------|-------------|-------|------------|-------|-------|
| Output Module Timing | | '-2' Speed | | '-1' Speed | | 'Std' Speed | | '-F' Speed | | |
| Parameter | Description | Min. | Max. | Min. | Max. | Min. | Max. | Min. | Max. | Units |
| TTL Output Module Timing¹ | | | | | | | | | | |
| t _{DLH} | Data-to-Pad HIGH | | 3.97 | | 4.50 | | 5.29 | | 7.41 | ns |
| t _{DHL} | Data-to-Pad LOW | | 4.61 | | 5.22 | | 6.15 | | 8.60 | ns |
| t _{ENZH} | Enable Pad Z to HIGH | | 4.13 | | 4.68 | | 5.50 | | 7.70 | ns |
| t _{ENZL} | Enable Pad Z to LOW | | 4.56 | | 5.16 | | 6.08 | | 8.51 | ns |
| t _{ENHZ} | Enable Pad HIGH to Z | | 8.18 | | 9.27 | | 10.91 | | 15.27 | ns |
| t _{ENLZ} | Enable Pad LOW to Z | | 7.63 | | 8.65 | | 10.18 | | 14.25 | ns |
| t _{GLH} | G-to-Pad HIGH | | 7.82 | | 8.87 | | 10.43 | | 14.60 | ns |
| t _{GHL} | G-to-Pad LOW | | 7.82 | | 8.87 | | 10.43 | | 14.60 | ns |
| t _{LSU} | I/O Latch Output Set-Up | 0.74 | | 0.83 | | 0.98 | | 1.37 | | ns |
| t _{LH} | I/O Latch Output Hold | 0.00 | | 0.00 | | 0.00 | | 0.00 | | ns |
| t _{LCO} | I/O Latch Clock-to-Out (Pad-to-Pad) 32 I/O | | 8.82 | | 10.00 | | 11.76 | | 16.46 | ns |
| t _{ACO} | Array Latch Clock-to-Out (Pad-to-Pad) 32 I/O | | 12.08 | | 13.69 | | 16.10 | | 22.54 | ns |
| d _{TLH} | Capacitive Loading, LOW to HIGH | | 0.11 | | 0.12 | | 0.14 | | 0.20 | ns/pF |
| d _{THL} | Capacitive Loading, HIGH to LOW | | 0.11 | | 0.12 | | 0.14 | | 0.20 | ns/pF |
| CMOS Output Module Timing¹ | | | | | | | | | | |
| t _{DLH} | Data-to-Pad HIGH | | 5.49 | | 6.22 | | 7.32 | | 10.25 | ns |
| t _{DHL} | Data-to-Pad LOW | | 3.82 | | 4.33 | | 5.10 | | 7.13 | ns |
| t _{ENZH} | Enable Pad Z to HIGH | | 4.13 | | 4.68 | | 5.50 | | 7.70 | ns |
| t _{ENZL} | Enable Pad Z to LOW | | 4.56 | | 5.16 | | 6.08 | | 8.51 | ns |
| t _{ENHZ} | Enable Pad HIGH to Z | | 8.18 | | 9.27 | | 10.91 | | 15.27 | ns |
| t _{ENLZ} | Enable Pad LOW to Z | | 7.63 | | 8.65 | | 10.18 | | 14.25 | ns |
| t _{GLH} | G-to-Pad HIGH | | 7.82 | | 8.87 | | 10.43 | | 14.60 | ns |
| t _{GHL} | G-to-Pad LOW | | 7.82 | | 8.87 | | 10.43 | | 14.60 | ns |
| t _{LSU} | I/O Latch Set-Up | 0.74 | | 0.83 | | 0.98 | | 1.37 | | ns |
| t _{LH} | I/O Latch Hold | 0.00 | | 0.00 | | 0.00 | | 0.00 | | ns |
| t _{LCO} | I/O Latch Clock-to-Out (Pad-to-Pad) 32 I/O | | 8.82 | | 10.00 | | 11.76 | | 16.46 | ns |
| t _{ACO} | Array Latch Clock-to-Out (Pad-to-Pad) 32 I/O | | 12.08 | | 13.69 | | 16.10 | | 22.54 | ns |
| d _{TLH} | Capacitive Loading, LOW to HIGH | | 0.11 | | 0.12 | | 0.14 | | 0.20 | ns/pF |
| d _{THL} | Capacitive Loading, HIGH to LOW | | 0.11 | | 0.12 | | 0.14 | | 0.20 | ns/pF |

Notes:

1. Routing delays are for typical designs across worst-case operating conditions. These parameters should be used for estimating device performance. Post-route timing analysis or simulation is required to determine actual worst-case performance.

Package Pin Assignments

44-Pin PLCC

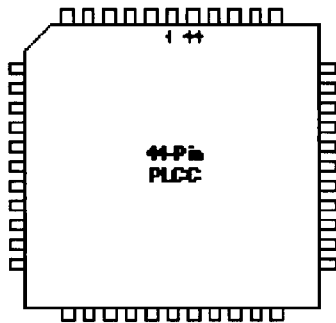

68-Pin PLCC

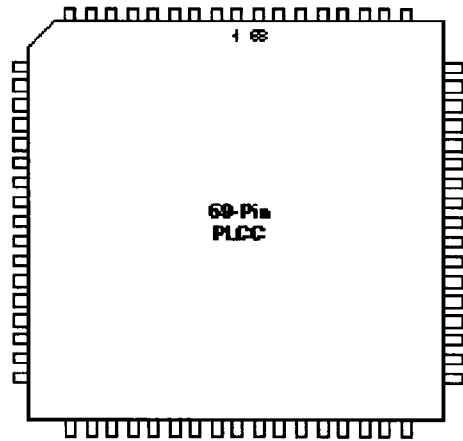

| Signal | A40MX02 Function | A40MX04 Function |
|--------|------------------|------------------|
| 3 | V _{CC} | V _{CC} |
| 10 | GND | GND |
| 14 | V _{CC} | V _{CC} |
| 16 | V _{CC} | V _{CC} |
| 21 | GND | GND |
| 25 | V _{CC} | V _{CC} |
| 32 | GND | GND |
| 33 | CLK, I/O | CLK, I/O |
| 34 | MODE | MODE |
| 35 | V _{CC} | V _{CC} |
| 36 | SDI, I/O | SDI, I/O |
| 37 | DCLK, I/O | DCLK, I/O |
| 38 | PRA, I/O | PRA, I/O |
| 39 | PRB, I/O | PRB, I/O |
| 43 | GND | GND |

| Signal | A40MX02 Function | A40MX04 Function |
|--------|------------------|------------------|
| 4 | V _{CC} | V _{CC} |
| 14 | GND | GND |
| 15 | GND | GND |
| 21 | V _{CC} | V _{CC} |
| 25 | V _{CC} | V _{CC} |
| 32 | GND | GND |
| 38 | V _{CC} | V _{CC} |
| 49 | GND | GND |
| 52 | CLK, I/O | CLK, I/O |
| 54 | MODE | MODE |
| 55 | V _{CC} | V _{CC} |
| 56 | SDI, I/O | SDI, I/O |
| 57 | DCLK, I/O | DCLK, I/O |
| 58 | PRA, I/O | PRA, I/O |
| 59 | PRB, I/O | PRB, I/O |
| 66 | GND | GND |

Package Pin Assignments (continued)

84-Pin PLCC

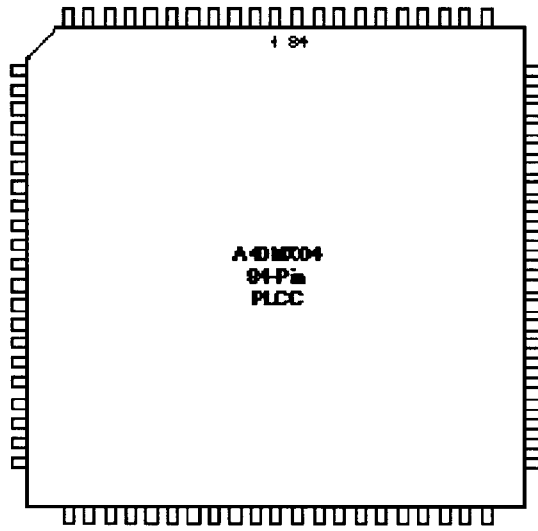

| Signal | A40MX04 Function |
|--------|---------------------|
| 4 | V _{CC} |
| 12 | NC |
| 18 | GND |
| 19 | GND |
| 25 | V _{CC} |
| 26 | V _{CC} |
| 33 | V _{CC} |
| 40 | GND |
| 46 | V _{CC} |
| 60 | GND |
| 61 | GND |
| 64 | CLK, I/O |
| 66 | MODE |
| 67 | V _{CC} |
| 68 | V _{CC} |
| 72 | SDI, I/O |
| 73 | DCLK, I/O |
| 74 | PRA, I/O |
| 75 | PRB, I/O |
| 82 | GND |

Notes:

1. NC Denotes 'No Connection'.
2. All unlisted pin numbers are user I/Os.
3. MODE should be terminated to GND through a 10K resistor to enable ActionProbe usage; otherwise, it can be terminated directly to GND.

Package Pin Assignments (continued)

100-Pin PQFP

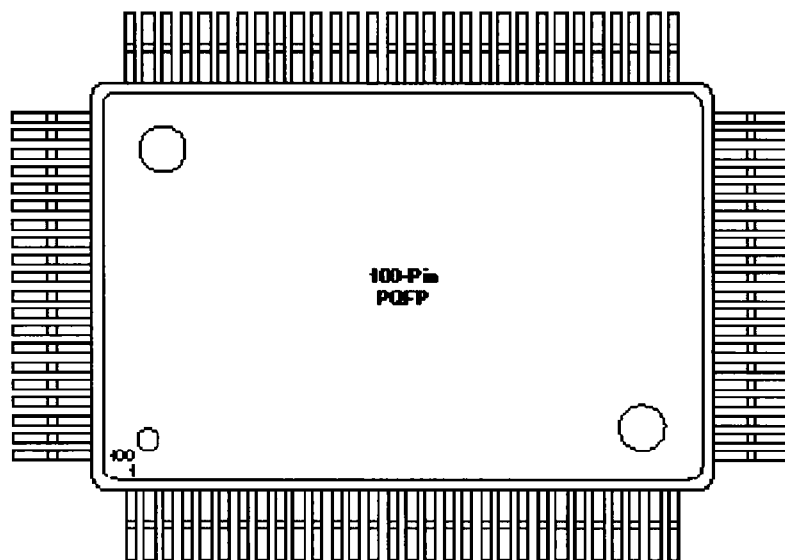

| Pin | A40MX02 Function | A40MX04 Function |
|-----|------------------|------------------|
| 1 | NC | NC |
| 2 | NC | NC |
| 3 | NC | NC |
| 4 | NC | NC |
| 5 | NC | NC |
| 6 | PRB, I/O | PRB, I/O |
| 13 | GND | GND |
| 19 | V _{CC} | V _{CC} |
| 27 | NC | NC |
| 28 | NC | NC |
| 29 | NC | NC |
| 30 | NC | NC |
| 31 | NC | I/O |
| 32 | NC | I/O |
| 33 | NC | I/O |
| 36 | GND | GND |
| 37 | GND | GND |
| 43 | V _{CC} | V _{CC} |
| 44 | V _{CC} | V _{CC} |
| 48 | NC | I/O |
| 49 | NC | I/O |
| 50 | NC | I/O |
| 51 | NC | NC |
| 52 | NC | NC |

| Pin | A40MX02 Function | A40MX04 Function |
|-----|------------------|------------------|
| 53 | NC | NC |
| 54 | NC | NC |
| 55 | NC | NC |
| 56 | V _{CC} | V _{CC} |
| 63 | GND | GND |
| 69 | V _{CC} | V _{CC} |
| 77 | NC | NC |
| 78 | NC | NC |
| 79 | NC | NC |
| 80 | NC | I/O |
| 81 | NC | I/O |
| 82 | NC | I/O |
| 86 | GND | GND |
| 87 | GND | GND |
| 90 | CLK, I/O | CLK, I/O |
| 92 | MODE | MODE |
| 93 | V _{CC} | V _{CC} |
| 94 | V _{CC} | V _{CC} |
| 95 | NC | I/O |
| 96 | NC | I/O |
| 97 | NC | I/O |
| 98 | SDI, I/O | SDI, I/O |
| 99 | DCLK, I/O | DCLK, I/O |
| 100 | PRA, I/O | PRA, I/O |

Notes:

1. NC Denotes 'No Connection'.
2. All unlisted pin numbers are user I/Os.
3. MODE should be terminated to GND through a 10K resistor to enable ActionProbe usage; otherwise, it can be terminated directly to GND.

Package Pin Assignments (continued)

80-Pin VQFP

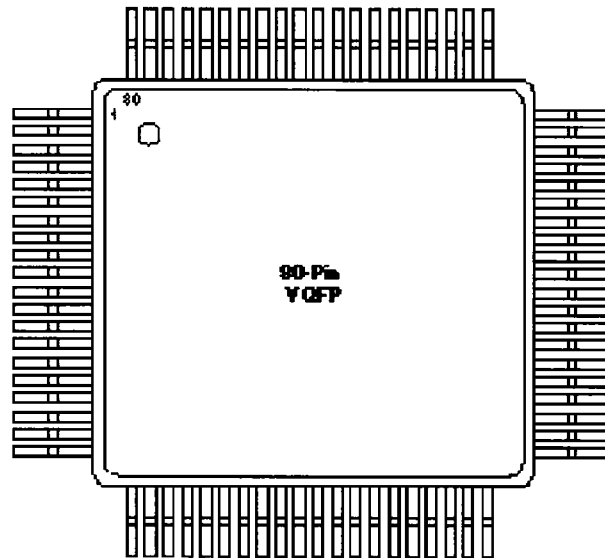

| Pin | A40MX02 Function | A40MX04 Function |
|-----|------------------|------------------|
| 2 | NC | I/O |
| 3 | NC | I/O |
| 4 | NC | I/O |
| 7 | GND | GND |
| 13 | V _{CC} | V _{CC} |
| 17 | NC | I/O |
| 18 | NC | I/O |
| 19 | NC | I/O |
| 20 | V _{CC} | V _{CC} |
| 27 | GND | GND |
| 33 | V _{CC} | V _{CC} |
| 41 | NC | I/O |
| 42 | NC | I/O |
| 43 | NC | I/O |

| Pin | A40MX02 Function | A40MX04 Function |
|-----|------------------|------------------|
| 47 | GND | GND |
| 50 | CLK, I/O | CLK, I/O |
| 52 | MODE | MODE |
| 53 | V _{CC} | V _{CC} |
| 54 | NC | I/O |
| 55 | NC | I/O |
| 56 | NC | I/O |
| 57 | SDI, I/O | SDI, I/O |
| 58 | DCLK, I/O | DCLK, I/O |
| 59 | PRA, I/O | PRA, I/O |
| 60 | NC | NC |
| 61 | PRB, I/O | PRB, I/O |
| 68 | GND | GND |
| 74 | V _{CC} | V _{CC} |

Notes:

1. NC Denotes 'No Connection'.
2. All unlisted pin numbers are user I/Os.
3. MODE should be terminated to GND through a 10K resistor to enable ActionProbe usage; otherwise, it can be terminated directly to GND.

Package Pin Assignments (continued)

84-Pin PLCC Package (Top View)

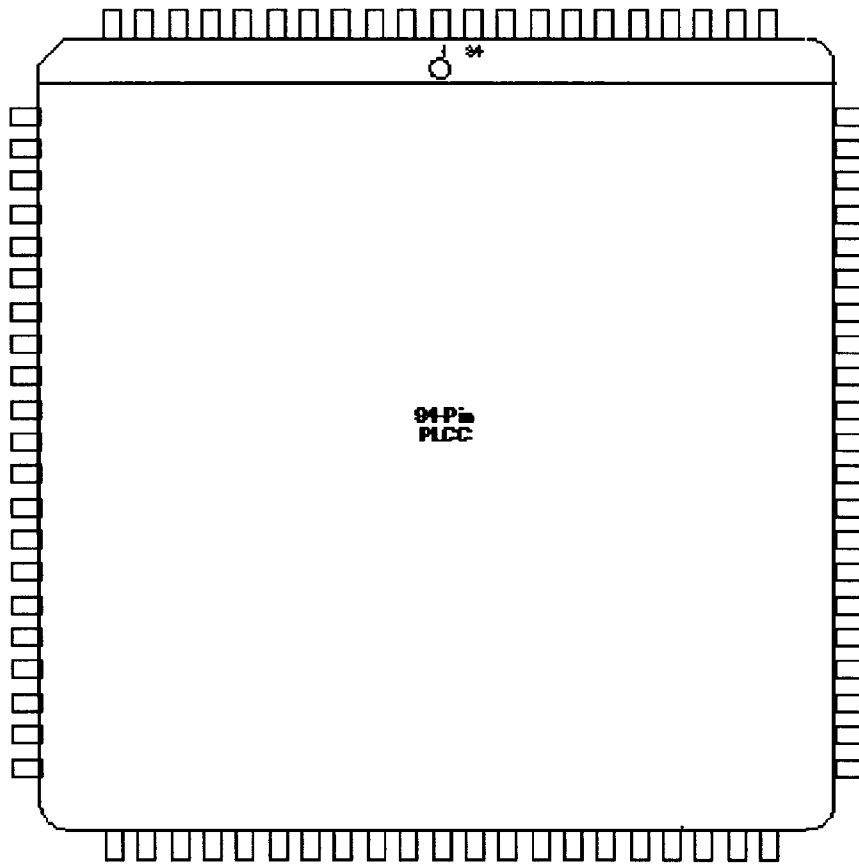

84-Pin PLCC Package

| Pin Number | A42MX09 Function | A42MX16 Function | A42MX24 Function |
|------------|------------------|------------------|------------------|
| 2 | CLKB, I/O | CLKB, I/O | CLKB, I/O |
| 4 | PRB, I/O | PRB, I/O | PRB, I/O |
| 5 | I/O | I/O | I/O (WD) |
| 6 | GND | GND | GND |
| 8 | I/O | I/O | I/O (WD) |
| 9 | I/O | I/O | I/O (WD) |
| 10 | DCLK, I/O | DCLK, I/O | DCLK, I/O |
| 12 | MODE | MODE | MODE |
| 22 | V _{CCI} | V _{CCI} | V _{CCI} |
| 23 | V _{CCA} | V _{CCA} | V _{CCA} |
| 28 | GND | GND | GND |
| 34 | I/O | I/O | TMS, I/O |
| 35 | I/O | I/O | TDI, I/O |
| 36 | I/O | I/O | I/O (WD) |
| 38 | I/O | I/O | I/O (WD) |
| 39 | I/O | I/O | I/O (WD) |
| 43 | V _{CCA} | V _{CCA} | V _{CCA} |
| 44 | I/O | I/O | I/O (WD) |
| 45 | I/O | I/O | I/O (WD) |
| 46 | I/O | I/O | I/O (WD) |
| 47 | I/O | I/O | I/O (WD) |
| 49 | GND | GND | GND |
| 50 | I/O | I/O | I/O (WD) |
| 51 | I/O | I/O | I/O (WD) |
| 52 | I/O | I/O | TDO (WD) |
| 62 | I/O | I/O | TCK, I/O |
| 63 | GND (LP) | GND (LP) | GND (LP) |
| 64 | V _{CCA} | V _{CCA} | V _{CCA} |
| 65 | V _{CCI} | V _{CCI} | V _{CCI} |
| 70 | GND | GND | GND |
| 76 | SDI, I/O | SDI, I/O | SDI, I/O |
| 78 | I/O | I/O | I/O (WD) |
| 79 | I/O | I/O | I/O (WD) |
| 80 | I/O | I/O | I/O (WD) |
| 81 | PRA, I/O | PRA, I/O | PRA, I/O |
| 83 | CLKA, I/O | CLKA, I/O | CLKA, I/O |
| 84 | V _{CCA} | V _{CCA} | V _{CCA} |

Notes:

1. I/O (WD): Denotes I/O pin with an associated wide-decode module.
2. Wide-decode I/O (WD) can also be general-purpose user I/O.
3. NC: Denotes 'No Connection'.
4. All unlisted pin numbers are user I/Os.
5. MODE should be terminated to GND through a 10K resistor to enable ActionProbe usage; otherwise, it can be terminated directly to GND.

Package Pin Assignments (continued)

100-Pin PQFP Package (Top View)

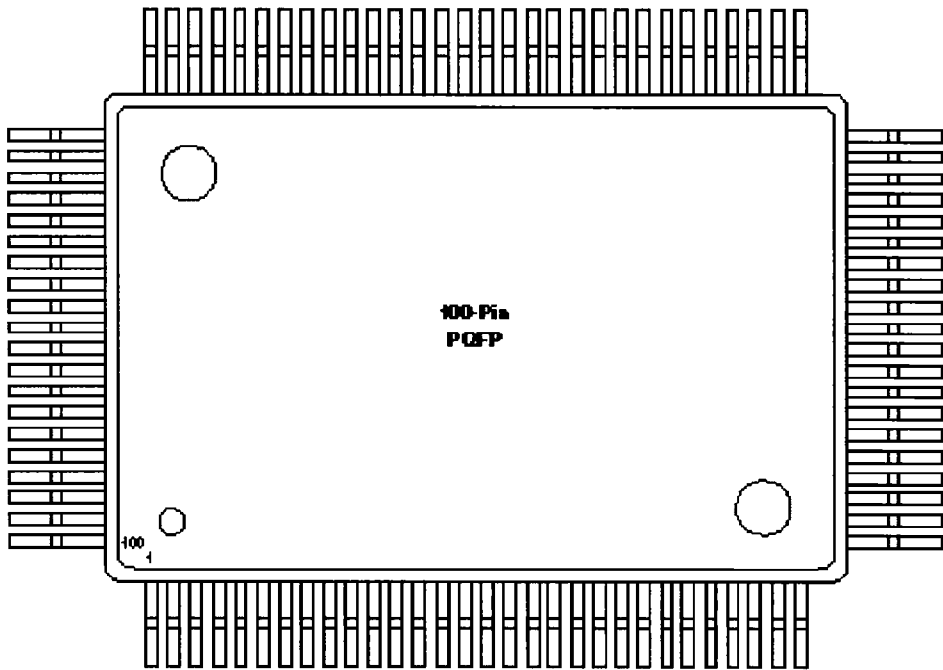

100-Pin PQFP Package

| Pin Number | A42MX09 PQ100 Function | A42MX16 PQ100 Function |
|------------|------------------------------|------------------------------|
| 2 | DCLK, I/O | DCLK, I/O |
| 4 | MODE | MODE |
| 7 | I/O | I/O |
| 9 | GND | GND |
| 14 | I/O | I/O |
| 15 | I/O | I/O |
| 16 | V _{CCA} | V _{CCA} |
| 17 | V _{CCI} | V _{CCA} |
| 20 | I/O | I/O |
| 22 | GND | GND |
| 32 | I/O | I/O |
| 34 | GND | GND |
| 38 | I/O | I/O |
| 40 | V _{CCA} | V _{CCA} |
| 44 | I/O | I/O |
| 46 | GND | GND |
| 55 | I/O | I/O |
| 57 | GND | GND |
| 62 | I/O | I/O |
| 63 | I/O | I/O |

| Pin Number | A42MX09 PQ100 Function | A42MX16 PQ100 Function |
|------------|------------------------------|------------------------------|
| 64 | GND (LP) | GND (LP) |
| 65 | V _{CCA} | V _{CCA} |
| 66 | V _{CCI} | V _{CCI} |
| 67 | V _{CCA} | V _{CCA} |
| 70 | I/O | I/O |
| 72 | GND | GND |
| 77 | I/O | I/O |
| 79 | SDI, I/O | SDI, I/O |
| 82 | I/O | I/O |
| 84 | GND | GND |
| 85 | I/O | I/O |
| 87 | PRA, I/O | PRA, I/O |
| 88 | I/O | I/O |
| 89 | CLKA, I/O | CLKA, I/O |
| 90 | V _{CCA} | V _{CCA} |
| 92 | CLKB, I/O | CLKB, I/O |
| 94 | PRB, I/O | PRB, I/O |
| 96 | GND | GND |
| 100 | I/O | I/O |

Notes:

1. NC: Denotes 'No Connection'.
2. All unlisted pin numbers are user I/Os.
3. MODE should be terminated to GND through a 10K resistor to enable ActionProbe usage; otherwise, it can be terminated directly to GND.

Package Pin Assignments (continued)

160-Pin PQFP Package (Top View)

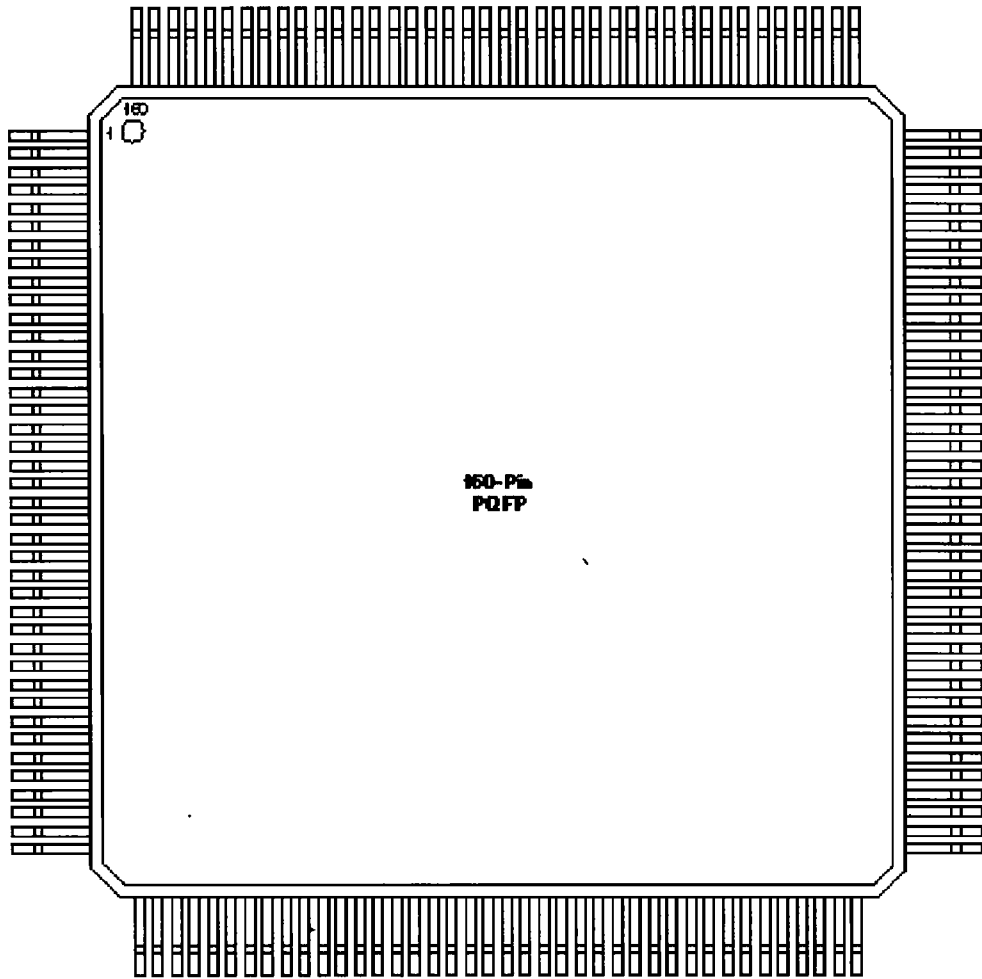

Notes:

1. I/O(WD): Denotes I/O pin with an associated wide-decode module.
2. Wide-decode I/O(WD) can also be general-purpose user I/O.
3. NC: Denotes 'No Connection'.
4. All unlisted pin numbers are user I/Os.
5. MODE should be terminated to GND through a 10K resistor to enable ActionProbe usage; otherwise, it can be terminated directly to GND.

160-Pin PQFP Package

| Pin Number | A42MX09 Function | A42MX16 Function | A42MX24 Function | Pin Number | A42MX09 Function | A42MX16 Function | A42MX24 Function |
|------------|------------------|------------------|------------------|------------|------------------|------------------|------------------|
| 2 | DCLK, I/O | DCLK, I/O | DCLK, I/O | 83 | I/O | I/O | I/O (WD) |
| 4 | I/O | I/O | I/O (WD) | 84 | I/O | I/O | I/O (WD) |
| 5 | I/O | I/O | I/O (WD) | 86 | NC | V _{CCI} | V _{CCI} |
| 6 | NC | V _{CCI} | V _{CCI} | 87 | I/O | I/O | I/O |
| 7 | I/O | I/O | I/O | 88 | I/O | I/O | I/O (WD) |
| 10 | NC | I/O | I/O | 89 | GND | GND | GND |
| 11 | GND | GND | GND | 92 | I/O | I/O | I/O |
| 12 | NC | I/O | I/O | 93 | I/O | I/O | I/O |
| 13 | I/O | I/O | I/O (WD) | 96 | I/O | I/O | I/O (WD) |
| 14 | I/O | I/O | I/O (WD) | 97 | I/O | I/O | I/O |
| 16 | PRB, I/O | PRB, I/O | PRB, I/O | 98 | V _{CCA} | V _{CCA} | V _{CCA} |
| 18 | CLKB, I/O | CLKB, I/O | CLKB, I/O | 99 | GND | GND | GND |
| 20 | V _{CCA} | V _{CCA} | V _{CCA} | 100 | NC | I/O | I/O |
| 21 | CLKA, I/O | CLKA, I/O | CLKA, I/O | 103 | NC | I/O | I/O |
| 23 | PRA, I/O | PRA, I/O | PRA, I/O | 106 | I/O | I/O | I/O (WD) |
| 24 | NC | I/O | I/O (WD) | 107 | I/O | I/O | I/O (WD) |
| 25 | I/O | I/O | I/O (WD) | 109 | GND | GND | GND |
| 26 | I/O | I/O | I/O | 110 | NC | I/O | I/O |
| 28 | NC | I/O | I/O | 111 | NC | I/O | I/O (WD) |
| 29 | I/O | I/O | I/O (WD) | 112 | I/O | I/O | I/O (WD) |
| 30 | GND | GND | GND | 114 | NC | V _{CCI} | V _{CCI} |
| 31 | NC | I/O | I/O (WD) | 115 | I/O | I/O | I/O (WD) |
| 34 | I/O | I/O | I/O | 116 | NC | I/O | I/O (WD) |
| 35 | NC | V _{CCI} | V _{CCI} | 118 | I/O | I/O | TDI, I/O |
| 36 | I/O | I/O | I/O (WD) | 119 | I/O | I/O | TMS, I/O |
| 37 | I/O | I/O | I/O (WD) | 120 | GND | GND | GND |
| 38 | SDI, I/O | SDI, I/O | SDI, I/O | 124 | NC | I/O | I/O |
| 40 | GND | GND | GND | 125 | NC | GND | GND |
| 44 | GND | GND | GND | 129 | NC | I/O | I/O |
| 49 | GND | GND | GND | 130 | GND | GND | GND |
| 52 | I/O | I/O | I/O | 131 | NC | I/O | I/O |
| 54 | NC | V _{CCA} | V _{CCA} | 135 | NC | V _{CCA} | V _{CCA} |
| 57 | V _{CCA} | V _{CCA} | V _{CCA} | 138 | NC | V _{CCA} | V _{CCA} |
| 58 | V _{CCI} | V _{CCI} | V _{CCI} | 139 | V _{CCI} | V _{CCI} | V _{CCI} |
| 59 | GND | GND | GND | 140 | GND | GND | GND |
| 60 | V _{CCA} | V _{CCA} | V _{CCA} | 141 | NC | I/O | I/O |
| 61 | GND (LP) | GND (LP) | GND (LP) | 145 | GND | GND | GND |
| 62 | I/O | I/O | TCK, I/O | 146 | NC | I/O | I/O |
| 64 | GND | GND | GND | 150 | NC | V _{CCA} | V _{CCA} |
| 69 | GND | GND | GND | 151 | NC | I/O | I/O |
| 70 | NC | I/O | I/O | 152 | NC | I/O | I/O |
| 75 | NC | I/O | I/O | 153 | NC | I/O | I/O |
| 77 | NC | I/O | I/O | 154 | NC | I/O | I/O |
| 79 | NC | I/O | I/O | 155 | GND | GND | GND |
| 80 | GND | GND | GND | 159 | MODE | MODE | MODE |
| 82 | I/O | I/O | TDO, I/O | 160 | GND | GND | GND |

Package Pin Assignments (continued)

208-Pin PQFP Package (Top View)

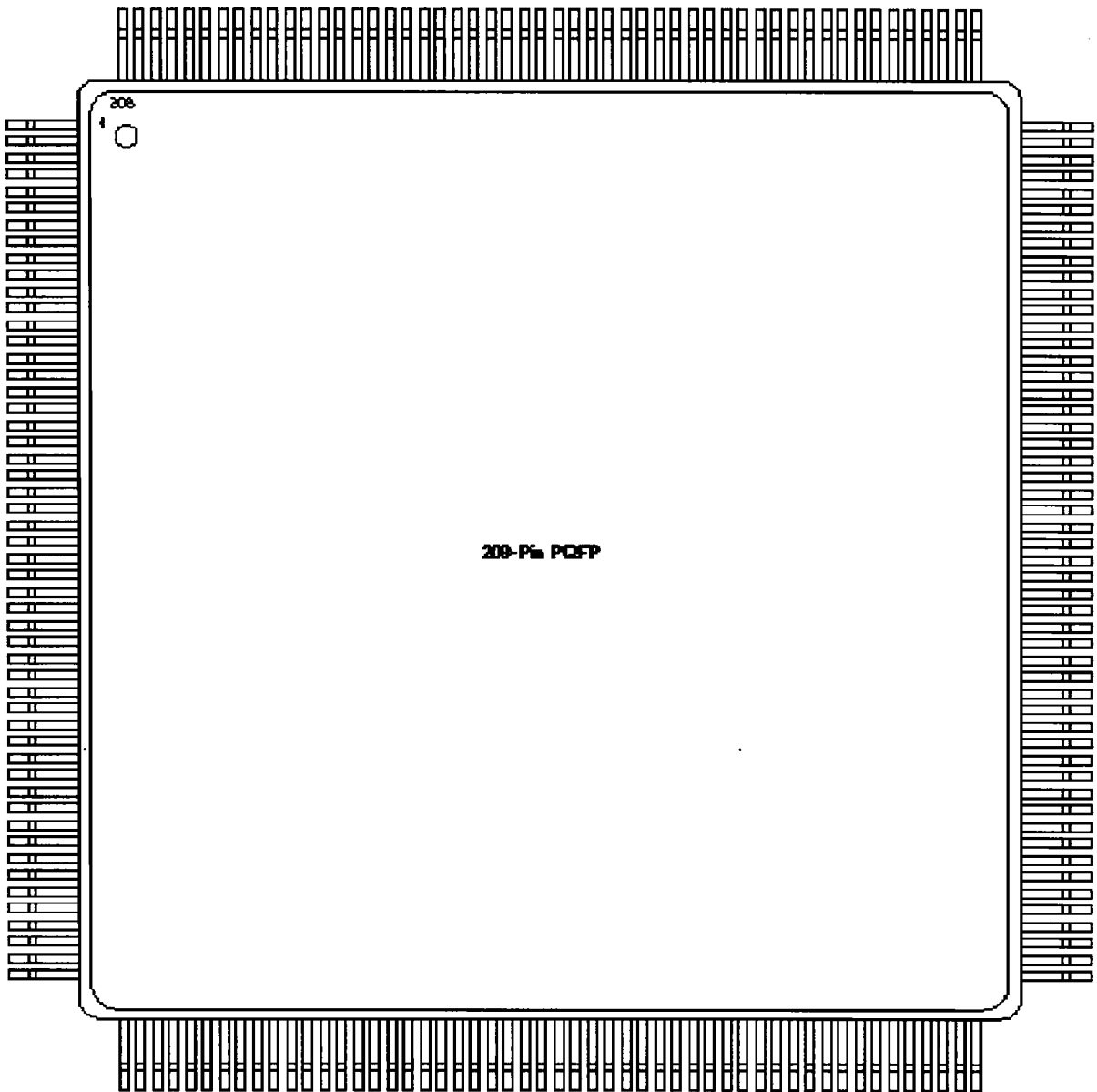

Notes:

1. I/O(WD): Denotes I/O pin with an associated wide-decode module.
2. Wide-decode I/O(WD) can also be general-purpose user I/O.
3. NC: Denotes 'No Connection'.
4. All unlisted pin numbers are user I/Os.
5. MODE should be terminated to GND through a 10K resistor to enable ActionProbe usage; otherwise, it can be terminated directly to GND.
6. RQFP has an exposed circular metal heat sink on the top surface.

208-Pin PQFP Package

| Pin Number | A42MX16 Function | A42MX24 Function | A42MX36 PQ208 Function |
|------------|---------------------|---------------------|---------------------------|
| 1 | GND | GND | GND |
| 2 | NC | V _{CCA} | V _{CCA} |
| 3 | MODE | MODE | MODE |
| 5 | I/O | I/O | I/O |
| 6 | I/O | I/O | I/O |
| 7 | I/O | I/O | I/O |
| 9 | NC | I/O | I/O |
| 10 | NC | I/O | I/O |
| 11 | NC | I/O | I/O |
| 13 | I/O | I/O | I/O |
| 15 | I/O | I/O | I/O |
| 16 | NC | I/O | I/O |
| 17 | V _{CCA} | V _{CCA} | V _{CCA} |
| 19 | I/O | I/O | I/O |
| 20 | I/O | I/O | I/O |
| 22 | GND | GND | GND |
| 24 | I/O | I/O | I/O |
| 26 | I/O | I/O | I/O |
| 27 | GND | GND | GND |
| 28 | V _{CCI} | V _{CCI} | V _{CCI} |
| 29 | V _{CCA} | V _{CCA} | V _{CCA} |
| 30 | I/O | I/O | I/O |
| 32 | V _{CCA} | V _{CCA} | V _{CCA} |
| 33 | I/O | I/O | I/O |
| 38 | I/O | I/O | I/O |
| 40 | I/O | I/O | I/O |
| 41 | NC | I/O | I/O |
| 42 | NC | I/O | I/O |
| 43 | NC | I/O | I/O |
| 45 | I/O | I/O | I/O |
| 47 | I/O | I/O | I/O |
| 48 | I/O | I/O | I/O |
| 50 | NC | I/O | I/O |
| 51 | NC | I/O | I/O |
| 52 | GND | GND | GND |
| 53 | GND | GND | GND |
| 54 | I/O | TMS, I/O | TMS, I/O |
| 55 | I/O | TDI, I/O | TDI, I/O |
| 57 | I/O | I/O (WD) | I/O (WD) |
| 58 | I/O | I/O (WD) | I/O (WD) |
| 59 | I/O | I/O | I/O |
| 60 | V _{CCI} | V _{CCI} | V _{CCI} |
| 61 | NC | I/O | I/O |
| 62 | NC | I/O | I/O |
| 65 | I/O | I/O | OCLKA, I/O |
| 66 | I/O | I/O (WD) | I/O (WD) |
| 67 | NC | I/O (WD) | I/O (WD) |
| 68 | NC | I/O | I/O |
| 70 | I/O | I/O (WD) | I/O (WD) |
| 71 | I/O | I/O (WD) | I/O (WD) |
| 74 | I/O | I/O | I/O |
| 77 | I/O | I/O | I/O |
| 78 | GND | GND | GND |
| 79 | V _{CCA} | V _{CCA} | V _{CCA} |
| 80 | NC | V _{CCI} | V _{CCI} |
| 81 | I/O | I/O | I/O |
| 83 | I/O | I/O | I/O |
| 85 | I/O | I/O (WD) | I/O (WD) |
| 86 | I/O | I/O (WD) | I/O (WD) |
| 89 | NC | I/O | I/O |
| 90 | NC | I/O | I/O |
| 91 | I/O | I/O | OCLKB, I/O |
| 93 | I/O | I/O (WD) | I/O (WD) |
| 94 | I/O | I/O (WD) | I/O (WD) |
| 95 | NC | I/O | I/O |
| 96 | NC | I/O | I/O |
| 97 | NC | I/O | I/O |
| 98 | V _{CCI} | V _{CCI} | V _{CCI} |
| 100 | I/O | I/O (WD) | I/O (WD) |
| 101 | I/O | I/O (WD) | I/O (WD) |
| 103 | I/O | TDO, I/O | TDO, I/O |

| Pin Number | A42MX16 Function | A42MX24 Function | A42MX36 PQ208 Function |
|------------|---------------------|---------------------|---------------------------|
| 104 | I/O | I/O | I/O |
| 105 | GND | GND | GND |
| 106 | NC | V _{CCA} | V _{CCA} |
| 107 | I/O | I/O | I/O |
| 108 | I/O | I/O | I/O |
| 110 | I/O | I/O | I/O |
| 112 | NC | I/O | I/O |
| 113 | NC | I/O | I/O |
| 114 | NC | I/O | I/O |
| 115 | NC | I/O | I/O |
| 117 | I/O | I/O | I/O |
| 121 | I/O | I/O | I/O |
| 122 | I/O | I/O | I/O |
| 126 | GND | GND | GND |
| 128 | I/O | TCK, I/O | TCK, I/O |
| 129 | GND (LP) | GND (LP) | GND (LP) |
| 130 | V _{CCA} | V _{CCA} | V _{CCA} |
| 131 | GND | GND | GND |
| 132 | V _{CCI} | V _{CCI} | V _{CCI} |
| 133 | V _{CCA} | V _{CCA} | V _{CCA} |
| 136 | V _{CCA} | V _{CCA} | V _{CCA} |
| 137 | I/O | I/O | I/O |
| 138 | I/O | I/O | I/O |
| 141 | NC | I/O | I/O |
| 142 | I/O | I/O | I/O |
| 144 | I/O | I/O | I/O |
| 146 | NC | I/O | I/O |
| 147 | NC | I/O | I/O |
| 148 | NC | I/O | I/O |
| 149 | NC | I/O | I/O |
| 150 | GND | GND | GND |
| 151 | I/O | I/O | I/O |
| 152 | I/O | I/O | I/O |
| 154 | I/O | I/O | I/O |
| 155 | I/O | I/O | I/O |
| 156 | I/O | I/O | I/O |
| 157 | GND | GND | GND |
| 159 | SDI, I/O | SDI, I/O | SDI, I/O |
| 161 | I/O | I/O (WD) | I/O (WD) |
| 162 | I/O | I/O (WD) | I/O (WD) |
| 164 | V _{CCI} | V _{CCI} | V _{CCI} |
| 165 | NC | I/O | I/O |
| 166 | NC | I/O | I/O |
| 168 | I/O | I/O (WD) | I/O (WD) |
| 169 | I/O | I/O (WD) | I/O (WD) |
| 171 | NC | I/O | OCLKD, I/O |
| 176 | I/O | I/O (WD) | I/O (WD) |
| 177 | I/O | I/O (WD) | I/O (WD) |
| 178 | PRA, I/O | PRA, I/O | PRA, I/O |
| 180 | CLKA, I/O | CLKA, I/O | CLKA, I/O |
| 181 | NC | I/O | I/O |
| 182 | NC | V _{CCI} | V _{CCI} |
| 183 | V _{CCA} | V _{CCA} | V _{CCA} |
| 184 | GND | GND | GND |
| 186 | CLKB, I/O | CLKB, I/O | CLKB, I/O |
| 187 | I/O | I/O | I/O |
| 188 | PRB, I/O | PRB, I/O | PRB, I/O |
| 190 | I/O | I/O (WD) | I/O (WD) |
| 191 | I/O | I/O (WD) | I/O (WD) |
| 193 | NC | I/O | I/O |
| 194 | NC | I/O (WD) | I/O (WD) |
| 195 | NC | I/O (WD) | I/O (WD) |
| 196 | I/O | I/O | OCLKC, I/O |
| 197 | NC | I/O | I/O |
| 201 | NC | I/O | I/O |
| 202 | V _{CCI} | V _{CCI} | V _{CCI} |
| 203 | I/O | I/O (WD) | I/O (WD) |
| 204 | I/O | I/O (WD) | I/O (WD) |
| 206 | I/O | I/O | I/O |
| 207 | DCLK, I/O | DCLK, I/O | DCLK, I/O |
| 208 | I/O | I/O | I/O |

Package Pin Assignments (continued)

240-Pin RQFP Package (Top View)

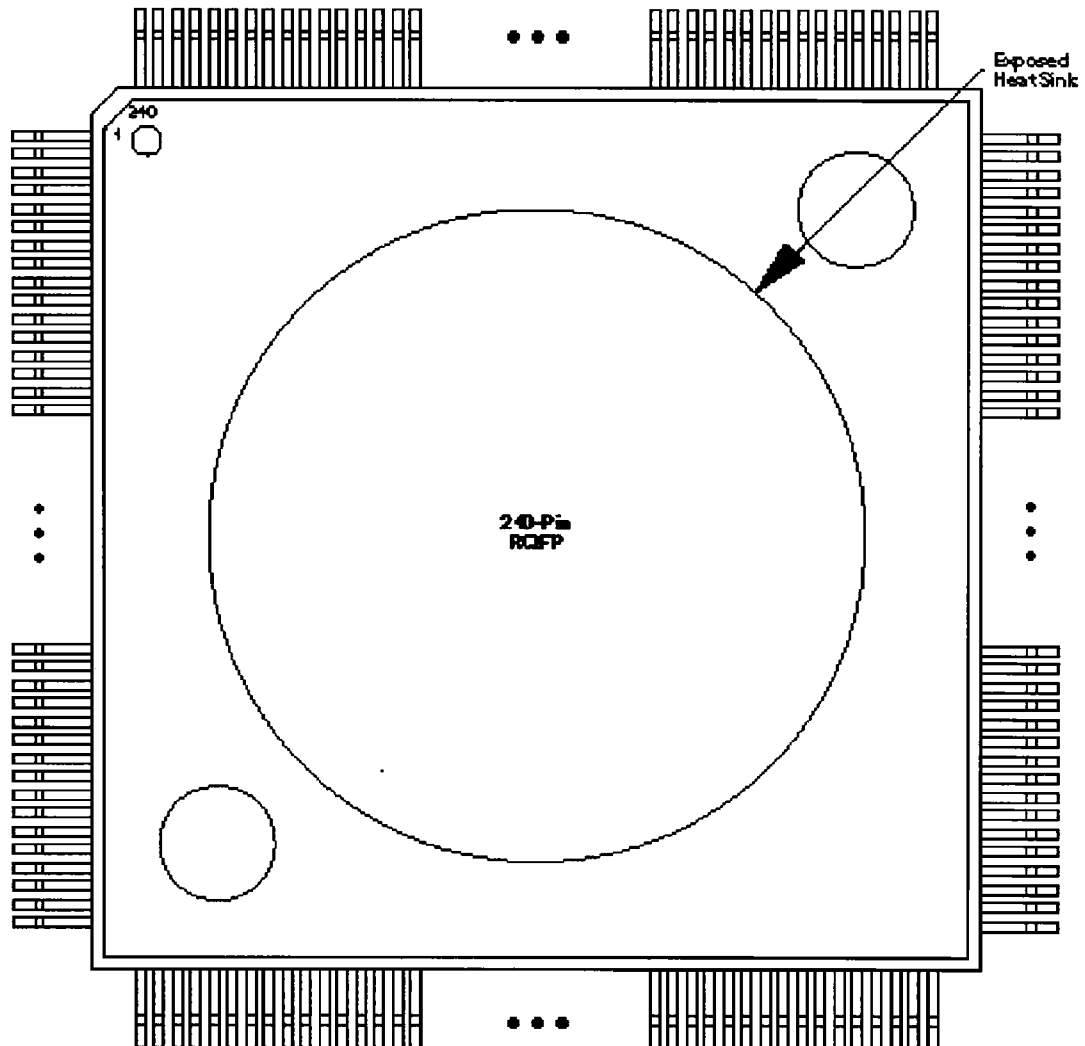

Notes:

1. I/O (WD): Denotes I/O pin with an associated wide-decode module.
2. Wide-decode I/O (WD) can also be general-purpose user I/O.
3. NC: Denotes 'No Connection'.
4. All unlisted pin numbers are user I/Os.
5. MODE should be terminated to GND through a 10K resistor to enable ActionProbe usage; otherwise, it can be terminated directly to GND.
6. RQFP has an exposed circular metal heat sink on the top surface.

240-Pin RQFP Package

| Pin Number | A42MX36 Function |
|------------|------------------|
| 2 | DCLK, I/O |
| 6 | I/O (WD) |
| 7 | I/O (WD) |
| 8 | V _{CCI} |
| 15 | QCLKC, I/O |
| 17 | I/O (WD) |
| 18 | I/O (WD) |
| 21 | I/O (WD) |
| 22 | I/O (WD) |
| 24 | PRB, I/O |
| 26 | CLKB, I/O |
| 28 | GND |
| 29 | V _{CCA} |
| 30 | V _{CCI} |
| 32 | CLKA, I/O |
| 34 | PRA, I/O |
| 37 | I/O (WD) |
| 38 | I/O (WD) |
| 45 | QCLKD, I/O |
| 47 | I/O (WD) |
| 48 | I/O (WD) |
| 52 | V _{CCI} |
| 54 | I/O (WD) |
| 55 | I/O (WD) |
| 57 | SDI, I/O |
| 59 | V _{CCA} |
| 60 | GND |
| 61 | GND |
| 71 | V _{CCI} |
| 85 | V _{CCA} |
| 88 | V _{CCA} |
| 89 | V _{CCI} |
| 90 | V _{CCA} |
| 91 | GND (LP) |
| 92 | TCK, I/O |
| 94 | GND |
| 108 | V _{CCI} |
| 118 | V _{CCA} |

| Pin Number | A42MX36 Function |
|------------|------------------|
| 119 | GND |
| 120 | GND |
| 121 | GND |
| 123 | TDO, I/O |
| 125 | I/O (WD) |
| 126 | I/O (WD) |
| 128 | V _{CCI} |
| 132 | I/O (WD) |
| 133 | I/O (WD) |
| 135 | QCLKB, I/O |
| 142 | I/O (WD) |
| 143 | I/O (WD) |
| 150 | V _{CCI} |
| 151 | V _{CCA} |
| 152 | GND |
| 159 | I/O (WD) |
| 160 | I/O (WD) |
| 163 | I/O (WD) |
| 164 | I/O (WD) |
| 166 | QCLKA, I/O |
| 172 | V _{CCI} |
| 174 | I/O (WD) |
| 175 | I/O (WD) |
| 178 | TDI, I/O |
| 179 | TMS, I/O |
| 180 | GND |
| 181 | V _{CCA} |
| 182 | GND |
| 192 | V _{CCI} |
| 206 | V _{CCA} |
| 209 | V _{CCA} |
| 210 | V _{CCI} |
| 219 | V _{CCA} |
| 227 | V _{CCI} |
| 237 | GND |
| 238 | MODE |
| 239 | V _{CCA} |
| 240 | GND |

Package Pin Assignments (continued)

176-Pin TQFP Package (Top View)

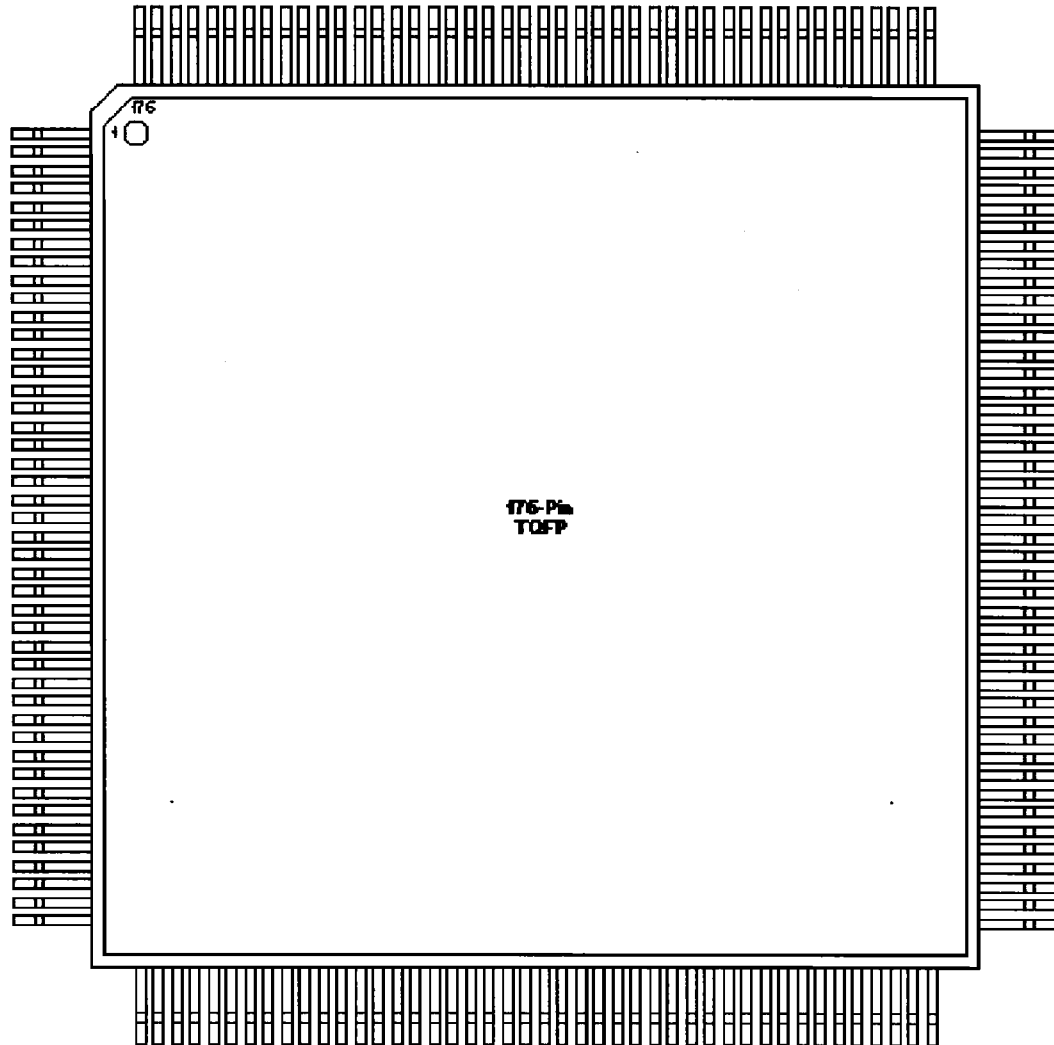

Notes:

1. I/O(WD): Denotes I/O pin with an associated wide-decode module.
2. Wide-decode I/O(WD) can also be general-purpose user I/O.
3. NC: Denotes 'No Connection'.
4. All unlisted pin numbers are user I/Os.
5. MODE should be terminated to GND through a 10K resistor to enable ActionProbe usage; otherwise, it can be terminated directly to GND.

176-Pin TQFP Package

| Pin Number | A42MX09 Function | A42MX16 Función | A42MX24 Function |
|------------|---------------------|--------------------|---------------------|
| 1 | GND | GND | GND |
| 2 | MODE | MODE | MODE |
| 8 | NC | NC | I/O |
| 10 | NC | I/O | I/O |
| 11 | NC | I/O | I/O |
| 13 | NC | V _{CCA} | V _{CCA} |
| 18 | GND | GND | GND |
| 19 | NC | I/O | I/O |
| 20 | NC | I/O | I/O |
| 22 | NC | I/O | I/O |
| 23 | GND | GND | GND |
| 24 | NC | V _{CCI} | V _{CCI} |
| 25 | V _{CCA} | V _{CCA} | V _{CCA} |
| 26 | NC | I/O | I/O |
| 27 | NC | I/O | I/O |
| 28 | V _{CCI} | V _{CCA} | V _{CCA} |
| 29 | NC | I/O | I/O |
| 33 | NC | NC | I/O |
| 37 | NC | I/O | I/O |
| 38 | NC | NC | I/O |
| 45 | GND | GND | GND |
| 46 | I/O | I/O | TMS, I/O |
| 47 | I/O | I/O | TDI, I/O |
| 48 | I/O | I/O | I/O |
| 49 | I/O | I/O | I/O (WD) |
| 50 | I/O | I/O | I/O (WD) |
| 52 | NC | V _{CCI} | V _{CCI} |
| 54 | NC | I/O | I/O |
| 55 | NC | I/O | I/O (WD) |
| 56 | I/O | I/O | I/O (WD) |
| 57 | NC | NC | I/O |
| 59 | I/O | I/O | I/O (WD) |
| 60 | I/O | I/O | I/O (WD) |
| 61 | NC | I/O | I/O |
| 64 | NC | I/O | I/O |
| 66 | NC | I/O | I/O |
| 67 | GND | GND | GND |
| 68 | V _{CCA} | V _{CCA} | V _{CCA} |
| 69 | I/O | I/O | I/O (WD) |
| 70 | I/O | I/O | I/O (WD) |
| 73 | I/O | I/O | I/O |
| 74 | NC | I/O | I/O |
| 75 | I/O | I/O | I/O |
| 77 | NC | NC | I/O (WD) |
| 78 | NC | I/O | I/O (WD) |
| 80 | NC | I/O | I/O |
| 81 | I/O | I/O | I/O |
| 82 | NC | V _{CCI} | V _{CCI} |
| 84 | I/O | I/O | I/O (WD) |
| 85 | I/O | I/O | I/O (WD) |
| 86 | NC | I/O | I/O |
| 87 | I/O | I/O | TDO, I/O |
| 89 | GND | GND | GND |
| 96 | NC | I/O | I/O |

| Pin Number | A42MX09 Function | A42MX16 Function | A42MX24 Function |
|------------|---------------------|---------------------|---------------------|
| 97 | NC | I/O | I/O |
| 101 | NC | NC | I/O |
| 103 | NC | I/O | I/O |
| 106 | GND | GND | GND |
| 107 | NC | I/O | I/O |
| 108 | NC | I/O | TCK, I/O |
| 109 | GND (LP) | GND (LP) | GND (LP) |
| 110 | V _{CCA} | V _{CCA} | V _{CCA} |
| 111 | GND | GND | GND |
| 112 | V _{CCI} | V _{CCI} | V _{CCI} |
| 113 | V _{CCA} | V _{CCA} | V _{CCA} |
| 114 | NC | I/O | I/O |
| 115 | NC | I/O | I/O |
| 116 | NC | V _{CCA} | V _{CCA} |
| 117 | I/O | I/O | I/O |
| 121 | NC | NC | I/O |
| 124 | NC | I/O | I/O |
| 125 | NC | I/O | I/O |
| 126 | NC | NC | I/O |
| 133 | GND | GND | GND |
| 135 | SDI, I/O | SDI, I/O | SDI, I/O |
| 136 | NC | I/O | I/O |
| 137 | I/O | I/O | I/O (WD) |
| 138 | I/O | I/O | I/O (WD) |
| 139 | I/O | I/O | I/O |
| 140 | NC | V _{CCI} | V _{CCI} |
| 141 | I/O | I/O | I/O |
| 143 | NC | I/O | I/O |
| 144 | NC | I/O | I/O (WD) |
| 145 | NC | NC | I/O (WD) |
| 146 | I/O | I/O | I/O |
| 147 | NC | I/O | I/O |
| 149 | I/O | I/O | I/O |
| 150 | I/O | I/O | I/O (WD) |
| 151 | NC | I/O | I/O (WD) |
| 152 | PRA, I/O | PRA, I/O | PRA, I/O |
| 154 | CLKA, I/O | CLKA, I/O | CLKA, I/O |
| 155 | V _{CCA} | V _{CCA} | V _{CCA} |
| 156 | GND | GND | GND |
| 158 | CLKB, I/O | CLKB, I/O | CLKB, I/O |
| 160 | PRB, I/O | PRB, I/O | PRB, I/O |
| 161 | NC | I/O | I/O (WD) |
| 162 | I/O | I/O | I/O (WD) |
| 163 | I/O | I/O | I/O |
| 165 | NC | NC | I/O (WD) |
| 166 | NC | I/O | I/O (WD) |
| 168 | NC | I/O | I/O |
| 169 | I/O | I/O | I/O |
| 170 | NC | V _{CCI} | V _{CCI} |
| 171 | I/O | I/O | I/O (WD) |
| 172 | I/O | I/O | I/O (WD) |
| 173 | NC | I/O | I/O |
| 175 | DCLK, I/O | DCLK, I/O | DCLK, I/O |

Package Mechanical Drawings

Plastic Leaded Chip Carrier (PLCC)

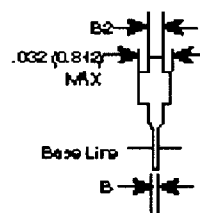
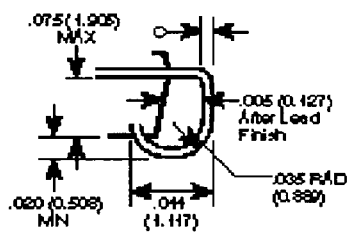
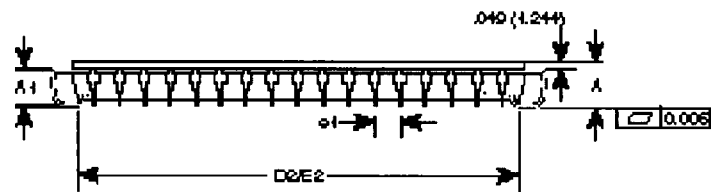
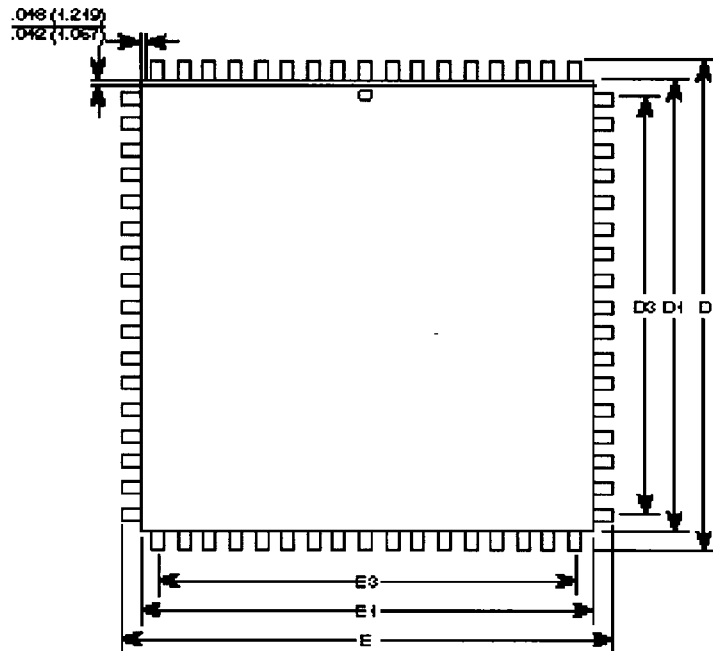



Plastic Leaded Chip Carrier Packages (PLCC)

| JEDEC Equivalent | PLCC 44 MS007 AE VAR | | PLCC 68 MS007 AE VAR | | PLCC 84 MS007 AE VAR | |
|------------------|-------------------------|-------|-------------------------|-------|-------------------------|-------|
| | Min. | Max. | Min. | Max. | Min. | Max. |
| A | 0.155 | 0.175 | 0.155 | 0.175 | 0.155 | 0.175 |
| A1 | 0.090 | 0.130 | 0.090 | 0.130 | 0.090 | 0.130 |
| B | 0.013 | 0.027 | 0.013 | 0.027 | 0.013 | 0.027 |
| B2 | 0.026 | 0.032 | 0.026 | 0.032 | 0.026 | 0.032 |
| C | 0.007 | 0.013 | 0.005 | 0.011 | 0.005 | 0.011 |
| D/E | 0.670 | 0.710 | 0.970 | 1.010 | 1.170 | 1.210 |
| D1/E1 | 0.640 | 0.660 | 0.940 | 0.960 | 1.140 | 1.160 |
| D2/E2 | 0.590 | 0.630 | 0.890 | 0.930 | 1.090 | 1.130 |
| D3/E3 | .50 nominal | | .80 nominal | | 1.00 nominal | |
| e1 | 0.050 BSC | | 0.050 BSC | | 0.050 BSC | |

Notes:

1. All dimensions are in inches.
2. BSC—Basic Spacing between Centers.

Package Mechanical Drawings (continued)

Plastic Quad Flat Pack (PQFP, RQFP, TQFP, VQFP)

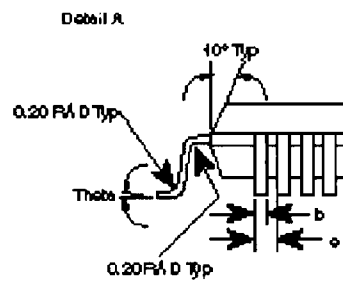
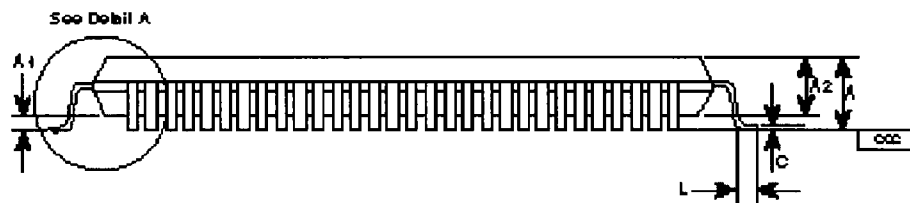
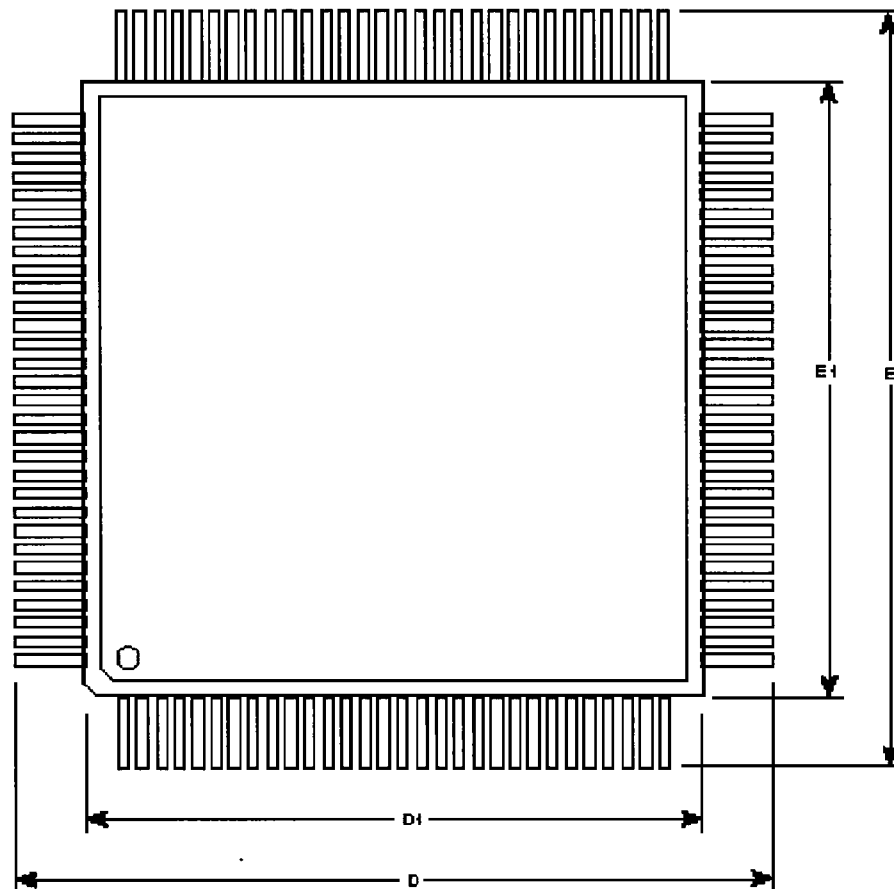

Package Mechanical Drawings (continued)

Plastic Quad Flat Pack
 Rectangular Package (PQ100)

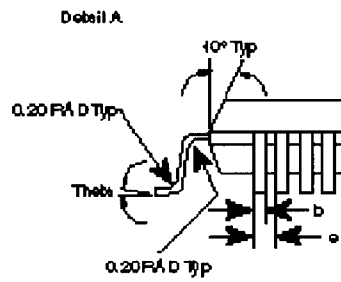
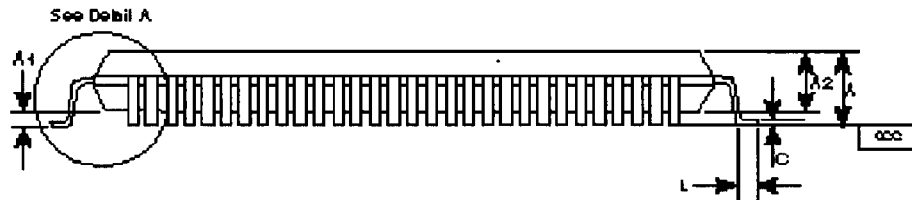
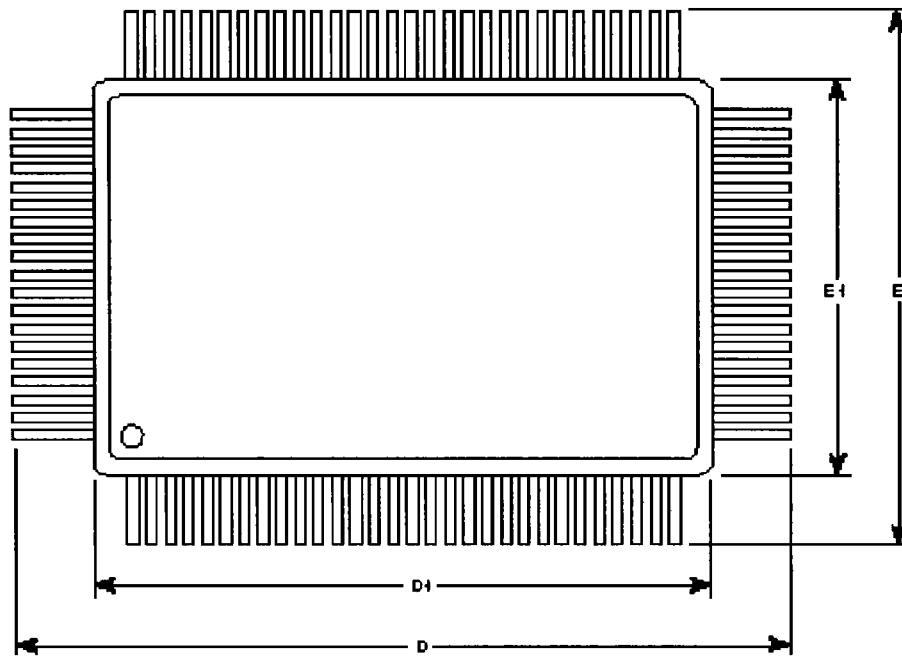

Plastic Quad Flat Packages (PQFP)

| JEDEC Equivalent | PQFP 100 MO-108 | | PQFP 160 MO-112 | | PQFP 208 MO-143 | |
|------------------|--------------------|-------|--------------------|-------|--------------------|-------|
| | Min. | Max. | Min. | Max. | Min. | Max. |
| A | | 3.40 | | 4.07 | | 4.10 |
| A1 | 0.25 | | 0.25 | | 0.25 | |
| A2 | 2.55 | 3.05 | 3.17 | 3.67 | 3.20 | 3.60 |
| b | 0.22 | 0.38 | 0.22 | 0.38 | 0.17 | 0.27 |
| c | 0.13 | 0.23 | 0.13 | 0.23 | 0.09 | 0.20 |
| D | 23.20 BSC | | 31.90 BSC | | 30.60 BSC | |
| D1 | 20.00 BSC | | 28.00 BSC | | 28.00 BSC | |
| E | 17.20 BSC | | 31.90 BSC | | 30.60 BSC | |
| E1 | 14.00 BSC | | 28.00 BSC | | 28.00 BSC | |
| e | 0.65 BSC | | 0.65 BSC | | 0.50 BSC | |
| L | 0.73 | 1.03 | 0.65 | 0.95 | 0.50 | 0.75 |
| ccc | | 0.10 | | 0.10 | | 0.08 |
| Theta | 0 | 7 deg | 0 | 7 deg | 0 | 7 deg |

Notes:

1. All dimensions are in millimeters.
2. BSC—Basic Spacing between Centers.

Plastic Quad Flat Packages (RQFP)

| JEDEC Equivalent | RQFP 240 MO-143 | |
|------------------|--------------------|-------|
| | Min. | Max. |
| A | | 4.10 |
| A1 | 0.25 | |
| A2 | 3.20 | 3.60 |
| b | 0.17 | 0.27 |
| c | 0.09 | 0.20 |
| D/E | 34.60 BSC | |
| D1/E1 | 32.00 BSC | |
| e | 0.50 BSC | |
| L | 0.50 | 0.75 |
| ccc | | 0.08 |
| Theta | 0 | 7 deg |

Notes:

1. All dimensions are in millimeters.
2. BSC—Basic Spacing between Centers.

Thin Quad Flat Packs (TQFP and VQFP)

| JEDEC Equivalent | TQFP 176 MO-136 | | VQFP 80 MO-136 | |
|------------------|--------------------|-------|-------------------|-------|
| | Min. | Max. | Min. | Max. |
| A | | 1.60 | | 1.20 |
| A1 | 0.05 | 0.15 | 0.05 | 0.15 |
| A2 | 1.35 | 1.45 | 0.95 | 1.05 |
| b | 0.17 | 0.27 | 0.22 | 0.38 |
| c | 0.09 | 0.20 | 0.09 | 0.20 |
| D/E | 26.00 BSC | | 16.00 BSC | |
| D1/E1 | 24.00 BSC | | 14.00 BSC | |
| e | 0.50 BSC | | 0.65 BSC | |
| L | 0.45 | 0.75 | 0.45 | 0.75 |
| ccc | | 0.08 | | 0.10 |
| Theta | 0 | 7 deg | 0 | 7 deg |

Notes:

1. All dimensions are in millimeters.
2. BSC—Basic Spacing between Centers.

Actel and the Actel logo are registered trademarks of Actel Corporation.
All other trademarks are the property of their owners.



Take it to a higher level.

<http://www.actel.com>

Actel Europe Ltd.

Daneshill House, Lutyens Close
Basingstoke, Hampshire RG24 8AG
United Kingdom

Tel: +44.(0)1256.305600

Fax: +44.(0)1256.355420

Actel Corporation

955 East Arques Avenue
Sunnyvale, California 94086
USA

Tel: 408.739.1010

Fax: 408.739.1540

Actel Japan

EXOS Ebisu Bldg. 4F
1-24-14 Ebisu Shibuya-ku
Tokyo 150 Japan

Tel: +81.(0)3.3445.7671

Fax: +81.(0)3.3445.7668

5172136-0